

## Safety of Fitness Equipment Cables

Ralph L. Barnett

Triodyne Inc.  
3054 North Lake Terrace  
Glenview, IL 60026  
(847) 677-4730, Fax (847) 647-2047  
infoserv@triodyne.com

Illinois Institute of Technology  
10 West 32nd Street  
Engineering 1 Building  
Chicago, IL 60616

### ABSTRACT

There is a family of fitness machines that provides a manual workout task requiring the user to push or pull against a resistance provided by a stack of weight plates. The weight system is usually linked with a single cable to a gripping or user interface device to produce a constant resistance. A fracture of the tensioned cable along its length or at its end connectors causes a sudden acceleration of the grip or other interface device driven by the operator's push or pull. The sudden loss of resistance often results in an exerciser pulling a heavy bar into his or her face. Because falling weights, accelerating grips and rapidly unloading muscles are all hazardous, manufacturers of exercise machines want to maintain the structural integrity of the cables. To accomplish this, manufacturers usually recommend "scheduled servicing" of their cables. This Preventive Maintenance (PM) strategy is frustrated by nylon sheathing that hides the cable failures. Further, the swaged or silver soldered connectors often fail covertly by internal fatigue fractures. A more effective PM strategy has been adopted by many manufacturers called "Scheduled Replacement"; they advocate annual cable replacement. Here the nemeses are sloth and greed, best expressed by the philosophy, "if it ain't broke, don't fix it." As a first consideration of fault tolerant design, a redundant duplication of the cable system was added to a fitness machine; this is called "active redundancy." This paper demonstrates the inadequacy of active redundancy for eliminating the catastrophic failure mode. Instead, the adoption of a "dormant/standby" redundancy is shown to provide the requisite safety. The proposed system not only eliminates the "fail-to-danger" mode, it provides the most economical use of the cable in the sense that it never discards a cable until its life is exhausted.

### INTRODUCTION

Cranes, elevators, and fitness machines all require tensile members that are variable length, high strength, lightweight, and flexible. The wire rope provides these properties with high reliability which is related to their multi-wire construction. Cranes and elevators expose wire rope to fluctuating stresses caused by variable

loading and their passage over sheaves and drums. Fatigue failure is a principal failure mode together with wear and overloading.

To minimize the danger of a dropped crane load, the wire rope is subjected to rigorous nondestructive inspection protocols. Furthermore, lifting practice discourages hoisting loads over personnel. With respect to elevators, the active redundancy of multiple ropes is backed up with safety systems that grab the guide rails if the cage descends too rapidly. The condition of the elevator rope may be monitored automatically, inspected manually, or replaced at predetermined intervals (e.g. 5 years). For both cranes and elevators, the wire ropes are always retired before their full life is utilized. This paper explores the use of various types of redundancy for improving the safety of fitness machines. These machines are especially challenging because their cables are encased in a nylon sheath that compromises their inspection.

Hanging weights are generally used to provide a constant resistance over the full pulling range on fitness equipment. These weights are usually suspended by a cable mechanism that transfers a selected gravity load to various portions of a human body through handles or foot pedals. This is illustrated by the stripped down fitness machine shown in Fig.1a. Manufacturers typically use an aircraft cable (seven strands with 19 wires per strand) that is 3/16 inch in diameter and covered in a nylon sheath. This highly redundant wire rope is composed of 133 wires; it uses end connectors that are usually swaged and/or silver soldered as shown in Figs. 1b through 1e.

Fitness equipment manufacturers generally advocate preventive maintenance (PM) techniques for maintaining the structural integrity of the cables. Preventive maintenance is defined as actions performed in an attempt to retain an item in a specified condition by providing systematic inspection, detection and prevention of incipient failure by repairing or replacing it. This concept must be contrasted with corrective maintenance which restores an item to a specified condition after it has failed. The two principal PM techniques are *scheduled servicing* and *scheduled replacement* [1, 2].

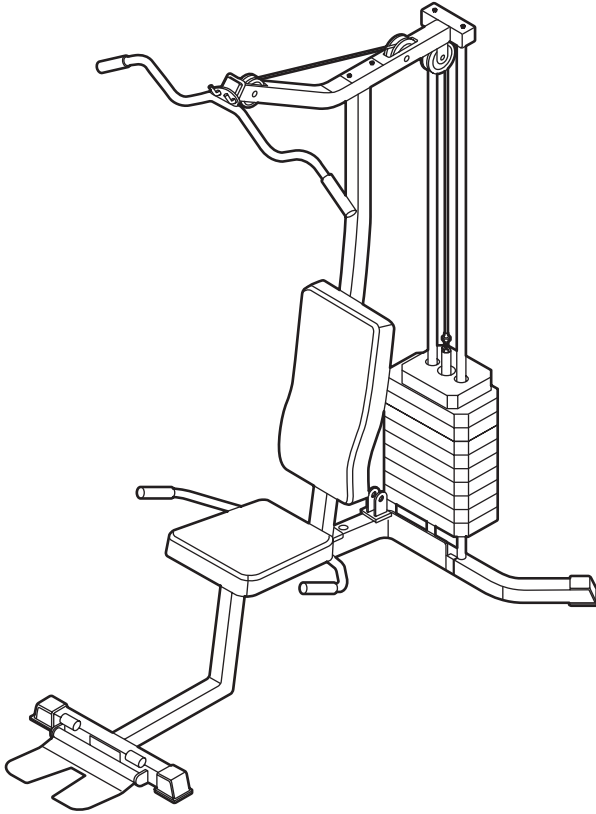

**Figure 1a. Fitness Machine**

## **SCHEDULED SERVICING**

Scheduled servicing is comprised of scheduled maintenance strategies which reveal incipient failures of items for the purpose of preventing system failures. Various servicing protocols are involved:

- A. Inspection – detection of self-revealing deteriorating conditions of items composing the system.
- B. Non-destructive testing – a body of testing techniques and methods which will not compromise the item tested.
- C. Cleaning
- D. Lubrication
- E. Calibration
- F. Adjustment
- G. Repair (if required)

In 2001, the following representatives of the fitness industry published recommendations for maintaining cables:

- **Body Master:** All belts and/or cables on all machines must be carefully inspected on a daily basis for any signs of wear, fraying, de-lamination and/or stretching. Replace worn or damaged belts (cables) immediately.
- **Pyramid:** Inspect cable wear (weekly).
- **Bally Total Fitness:** Inspect cables daily. Replace at first signs of wear.

These three recommendations precisely reflect the PM strategy called Scheduled Servicing. It is capable of detecting overt or self-revealing faults such as damaged sheathing. However, it is maintenance intensive and it is subject to human errors associated with subjective observations. Scheduled servicing will not detect covert faults such as the onset of fatigue failure.

Fatigue of wire rope manifests itself by successive failures of the constituent wires which form wire fractures – often called “fish hooks” – on the cable surface. Wire rope is a highly redundant tension member that communicates its compromised structural integrity before it fully separates [3]. Unfortunately, the nylon sheathing that covers most fitness machine cables hides most wire failures. Furthermore, wire rope failure may occur inside of the end fasteners where no visual feedback is available. The author has investigated cable failure caused entirely by such internal fatigue failure of the end fasteners without any other signs of distress on the cable itself.

## **SCHEDULED REPLACEMENT**

Scheduled replacement involves the replacement of parts at pre-determined times before failure. When the onset of failure of an item cannot be determined, scheduled replacement is the only PM strategy available. Reliability analysis techniques are required to develop replacement schedules that will minimize the number of items which fail. On the other hand, inefficient replacement or maintenance schedules may be adopted through trial and error or anecdotal observations.

The author’s survey of ten fitness organizations in 2001 uncovered the following additional guidelines for cable maintenance:

- **Icarian:** Replace cables annually.
- **Cybex:** Replace all cables at least annually.
- **Bodymaster:** All belts (cables) must be replaced every two years.
- **Bally Total Fitness:** All cables shall be changed annually or sooner as needed.

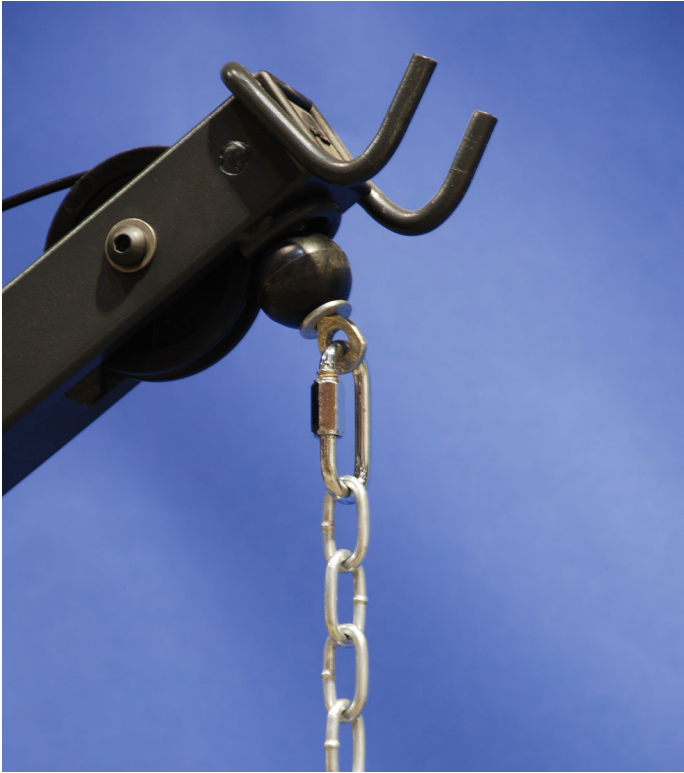

Figure 1b. Upper Termination

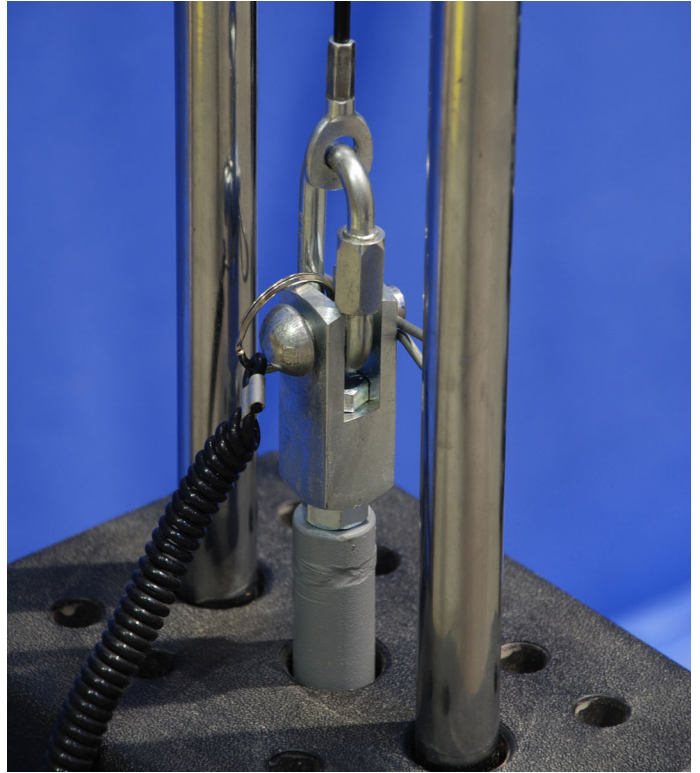

Figure 1d. Lower Termination



Figure 1c. Upper Termination



Figure 1e. Lower Termination



Observe that the above cited guidelines require cable replacement regardless of the condition of the wire rope. This is precisely the PM policy of Scheduled Replacement. Every one of the ten manufacturers in our small study required immediate cable replacement after wear was detected; but most did not specify replacement when no damage was detected.

Keeping track of the age of fitness machine cables requires discipline. Throwing away one-year-old cables with no apparent damage goes against the grain of frugality and resource conservation. “Changing out” cables that are inspected daily is work. Many sized new cables must be ordered and inventoried, and operations must be interrupted while new cables are installed. It is easier to ignore scheduled replacement and replace only broken cables or ones with compromised appearance.

The first remediation technique, Scheduled Servicing, is part of the Doctrine of Manifest Danger [3] and requires self-revealing deteriorating conditions. The second technique, Scheduled Replacement, requires a cable replacement interval that precludes cable failure. Both systems are active; diligent inspection schedules and regular replacement schedules are critical.

### FAIL-SAFE CABLE DESIGN

Because PM has not proven to be a satisfactory solution to the problem of cable fracture, it is reasonable to embrace the techniques of fail-safe design. The objective of a fail-safe design is to create a system that sets up a safe condition when a fault occurs. Specifically, failure of a cable should not result in a potential for injury or disaster. A straightforward approach to fail-safe design invokes an appeal to simple redundancy. Simple redundancy can be achieved by substituting two identical cable systems for the original cable system. This design is called Active Parallel Redundancy [4].

#### A. Active redundancy

Active redundancy is characterized as redundancy wherein all redundant items are operating simultaneously rather than being switched on when needed. The fitness machine illustrated in Fig. 1a was modified by duplicating the original cable system; the resulting redundant machine is shown in Fig. 2a. Because of symmetry, each of the cables shown in Fig. 2b shares the load equally. The resulting lower stress in each cable will extend its life. The conventional argument suggests that when one of the cables fails, the survivor will continue to carry the weights and the failed cable will give notice of the component failure. Upon reflection, this redundant design uses two already redundant nominally identical wire ropes which are woven using a large number of individual wires. The failure of a single wire rope proceeds by a succession of fatigue failures of the wire strands. Eventually, the surviving wires become sufficiently overloaded that the applied tensile stress exceeds the ultimate tensile resistance

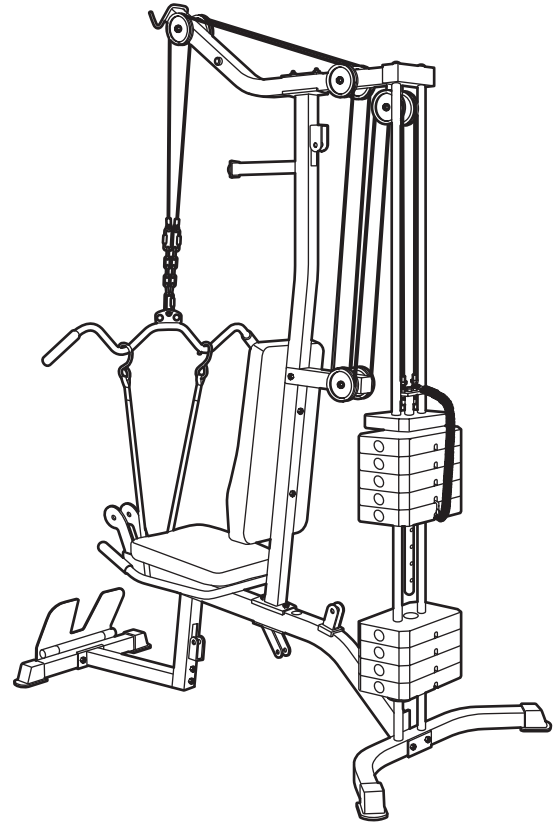

Figure 2a. Fitness Machine (Active Redundant Cable System)

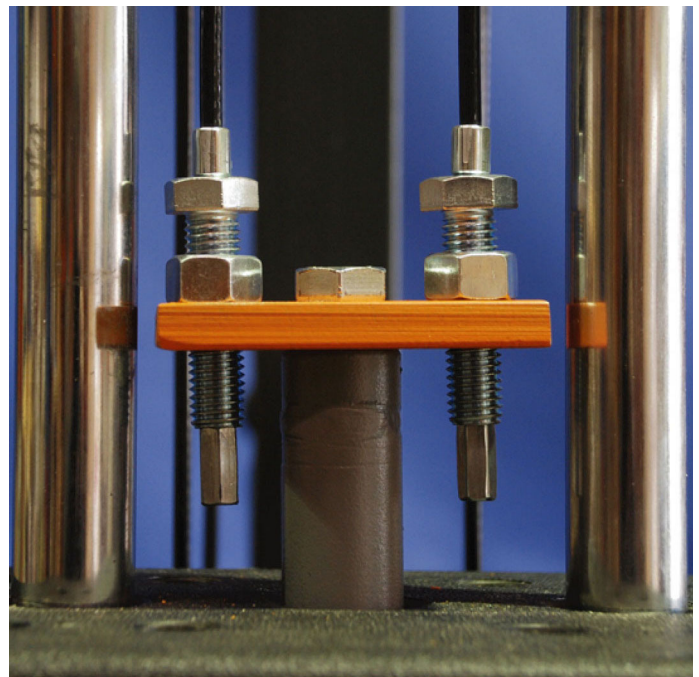

Figure 2b. Weight Stack Connection (Active Redundant Cable System)

of the wire strands. When two cables are loaded identically, one would expect the percentage of wire fractures in either cable to be roughly equivalent. Consequently, when one cable breaks, it subjects the other cable, which is on the brink of failing, to twice the applied load, usually causing it to fail as well. Theoretically, if each cable contained an infinite number of wires, both cables would break simultaneously. Because the number of wires is finite, one cable will always fail first.

As a demonstration of active redundancy one of the two new cables shown in Fig. 2b was deliberately cut. The surviving cable continued to equilibrate the load; this is conventional behavior. This test shows how active redundancy preserves the structural integrity of the cable system in the face of a random traumatic threat to one of the cables. PM will not provide this protection. As a second demonstration, one section of each cable was reduced from 133 wires to 6 wires as shown in Figs. 3a and 3b. Again, one of the cables was deliberately cut and the survivor immediately fractured because the six surviving wires could not support the entire weight stack as shown in Fig. 4.

In summary, active redundancy improves the system reliability. The simple act of redundancy will harden the system against random defects and traumatic insult to any one of the cables. However, the safety threat of fatigue failure is only prolonged because of the likelihood of dual cable system failure.

## B. Dormant Standby Redundancy

Because active parallel redundancy does not eliminate the possibility of cable system failure, a second type of failsafe design is proposed, Dormant Standby Redundancy [5]. Dormant standby redundancy is an alternative means of performing a function which is inoperative until needed; switched on upon failure of the primary means for performing the function. An example is the new spare tire in an automobile. The spare tire is not in use until it is substituted for a damaged tire by the automobile's operator. Another example is an ordinary scaffold system which has a new cable life line for each person using the scaffold. If the scaffold collapses, each of the workers is tied off to his own brand new lifeline which is entirely independent of the cables that are holding up the scaffold. The lifelines cannot be used again after a scaffold collapses. The American National Standard, ANSI A10.14-1991, American National Standard for Construction and Demolition Operations – Requirements for Safety Belts, Harnesses, Lanyards and Lifelines for Construction and Demolition Use states the following [6]:

*6.1.3 All fall protection systems subjected to impacts caused by a freefall or by testing shall be removed from service and should not be used again.*

As a consequence, scaffold workers are always protected by a new lifeline.

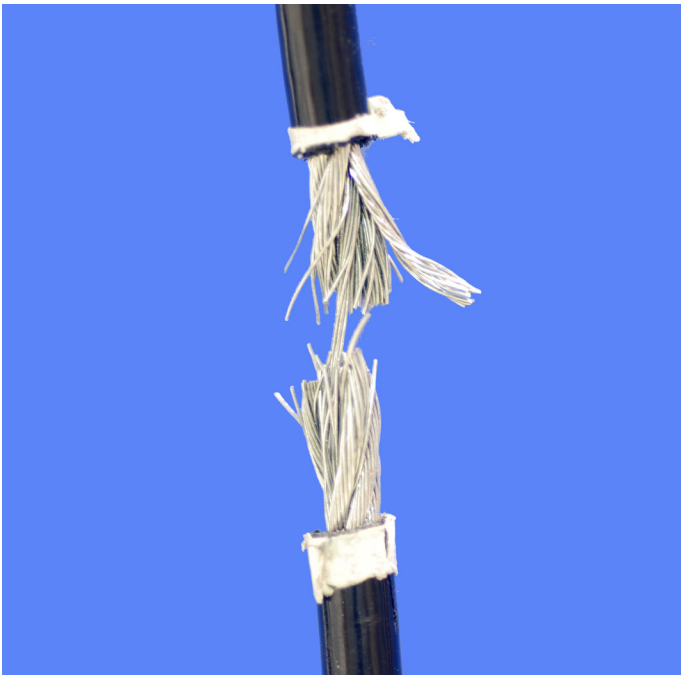

**Figure 3a.**  
**Left Cable Reduced to 6 Wires**

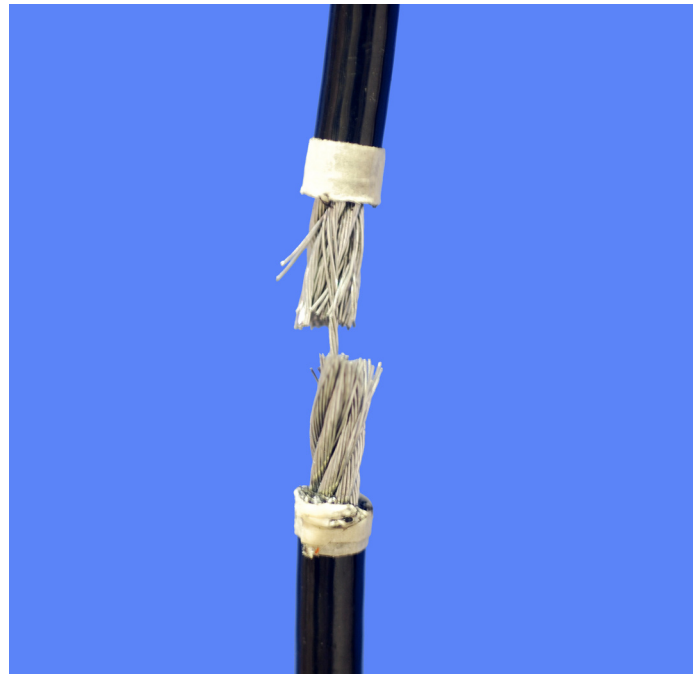
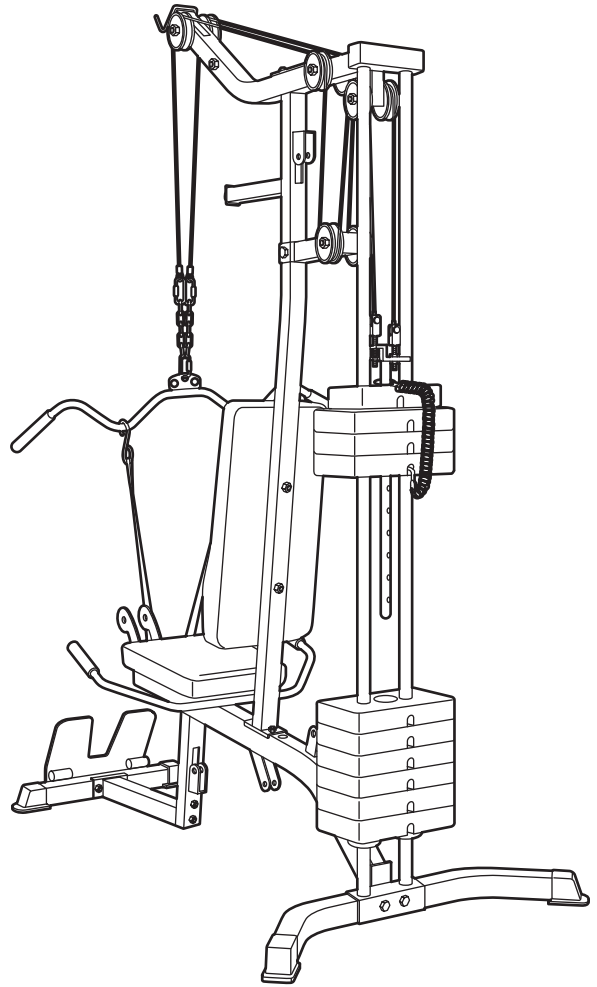

**Figure 3b.**  
**Right Cable Reduced to 6 Wires**

**Figure 3. Compromised Cables**



**Figure 4.**  
**Concurrent Cable Failures**



**Figure 5a. Dormant Standby Redundant Cable**

The proposed weight machine cable system is shown in Fig. 5a. The dual cables are affixed to the weight stack by the offset plate and compression spring depicted in Fig.5b. Any force applied to the left cable merely shortens the compression spring which limits the left cable loading to about 15 lb. Almost the entire weight stack is lifted by the right cable. If this right cable or its terminations are fractured because of trauma or fatigue, the weight is automatically switched to the “like new” left cable which bottoms out the compression spring as shown in Fig. 6 for a different style end connector. Observe in Fig.4 that the right cable assumes a serpentine geometry that notifies the operator of a component failure.

When the right cable fractures, its load is transferred to the left cable through a spring. The weight stack falls less than an inch. The broken cable manifests its fracture while an almost new cable continues to support the exercise activity. After the failure, the standby cable is moved to the right position to become the primary load bearing cable. A new cable is substituted for the left cable and becomes the dormant standby member. Observe that the full life of the right cable has been realized, whereas the scheduled replacement PM protocol throws away cables which may have substantial remaining life; indeed, the actual available cable life may be four or more times the “throwaway life.”

The dormant standby redundant cable system provides a flexible strategy that is easily applied to fitness machines with different configurations as shown in Figs.7, 8 and 9. Figure 10 replaces the compression spring with a gravity or spring loaded idler roller which takes up the slack in the dormant standby cable. The cylindrical compression spring can be replaced by a conical spring that provides a shorter compressed height. All of the proposed systems require an offset or phase shift between the parallel cable systems. In conventional elevators an increase in wire rope speed triggers the redundant grab rail safety system to engage.

## OBSERVATIONS

The original fitness machines were designed by fitness trainers who adopted the cable maintenance position “if it ain’t broke, don’t fit it” [7]. This strategy was later replaced by the notion, “if any cable defect manifests itself, replace the cable immediately.” No maintenance intervals or protocols were developed. Eventually, fitness machine manufacturers and health clubs began to embrace



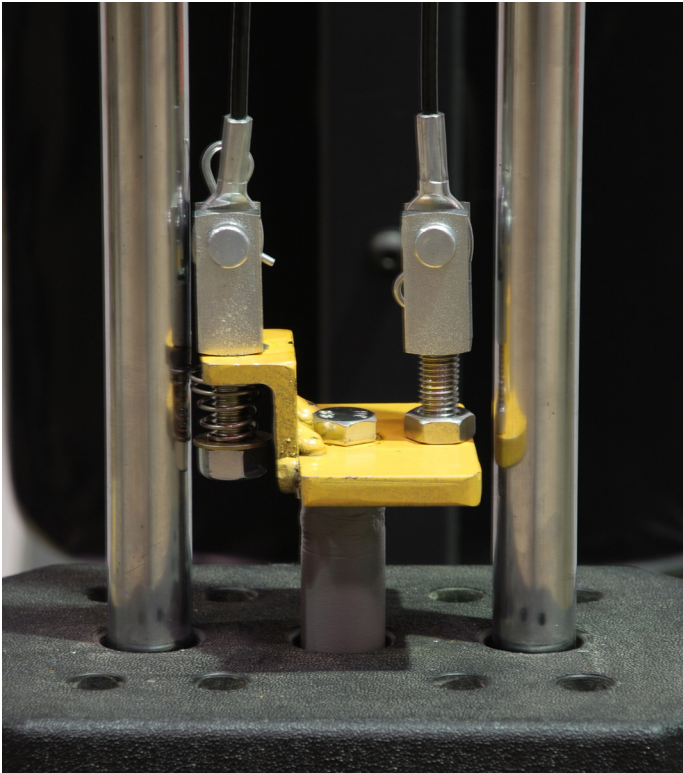

Figure 5b. Dormant Standby Redundant Cable

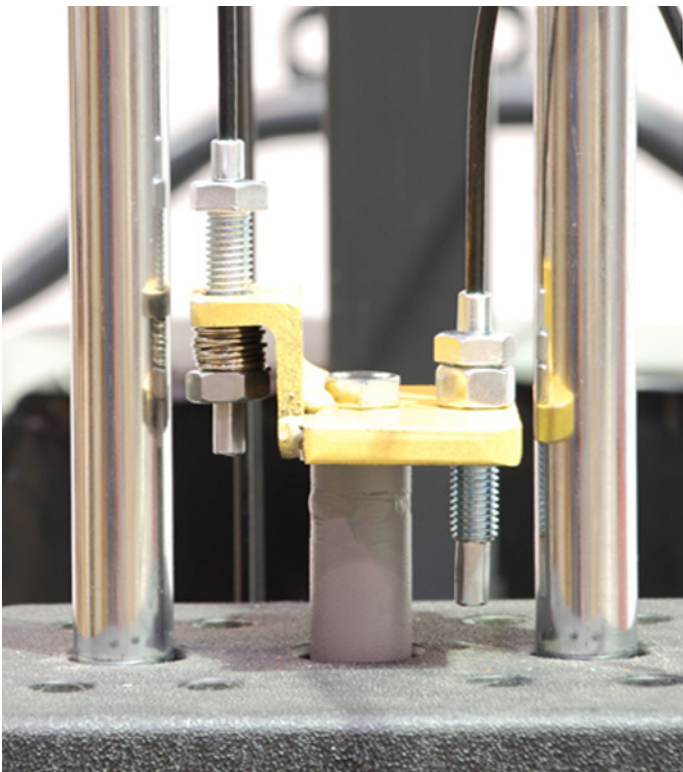

Figure 6. Compressed Spring on Surviving Cable

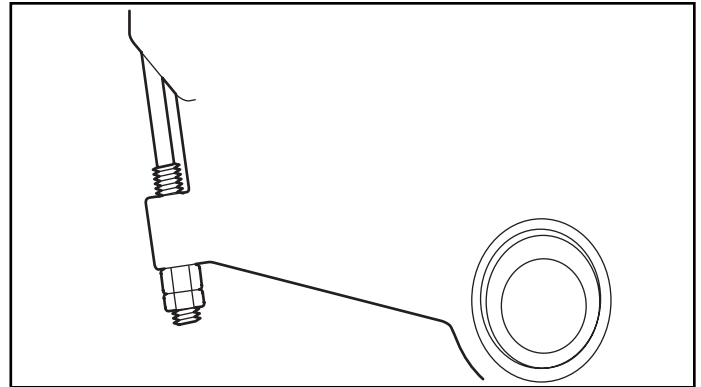

Figure 7a. Primary Cam Termination

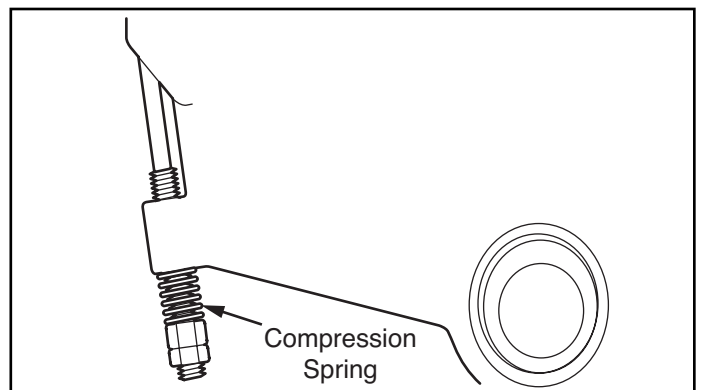

Figure 7b. Redundant Cam Termination With Spring Insert

a more disciplined maintenance approach called “scheduled servicing.” This preventative maintenance concept called for cable inspections to take place in various combinations of daily, weekly, monthly, and yearly. Today, the fitness industry has added a second PM concept called scheduled replacement. There is an admonition to replace the cables annually regardless of their appearance or condition. Typically, the replaced cables appear to be perfect; the one-year interval is very conservative.

The application of a fail-safe concept called dormant standby redundancy provides a brand new standby cable as a sentinel to keep watch over the original primary load carrying cable that supports the weight plates. Failure of the primary cable by the formation of overt faults, covert faults, or trauma, will cause a brand new cable to take over the function of the original load bearing cable system. This produces a quantum improvement in safety. Furthermore, the subjectiveness and human error associated with the PM strategies is almost completely eliminated with the use of the proposed fail-safe system.

The weak links in the cable systems associated with cranes, elevators, and fitness machines dictate when the wire ropes will be replaced. This premature retirement wastes the residual

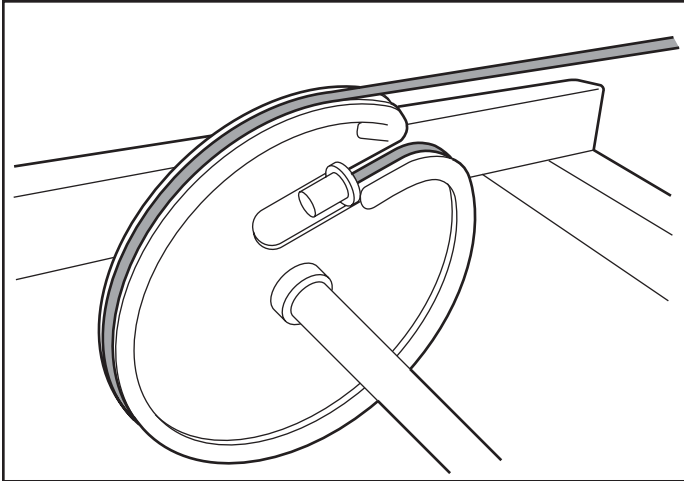

Figure 8a. Primary Cam Termination

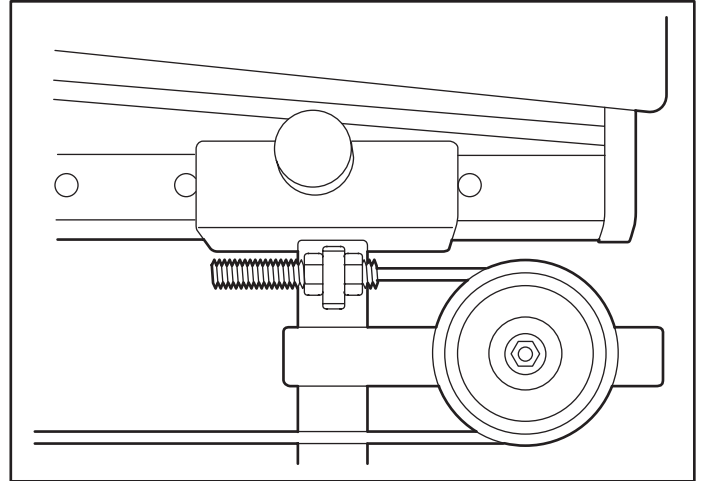

Figure 9a. Primary Cam Termination

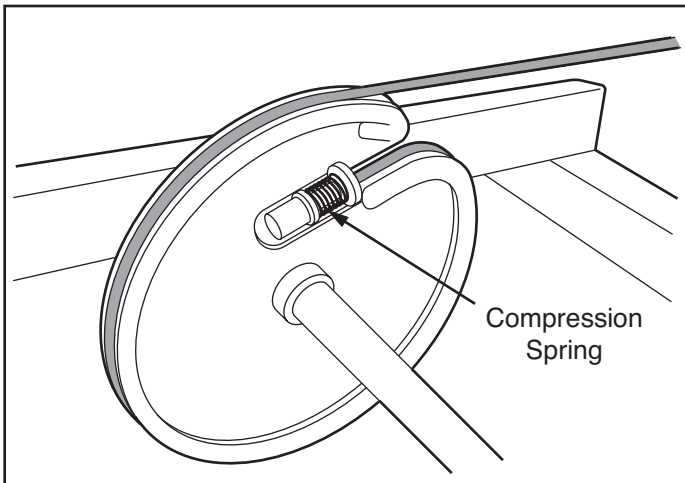

Figure 8b. Redundant Cam Termination With Spring

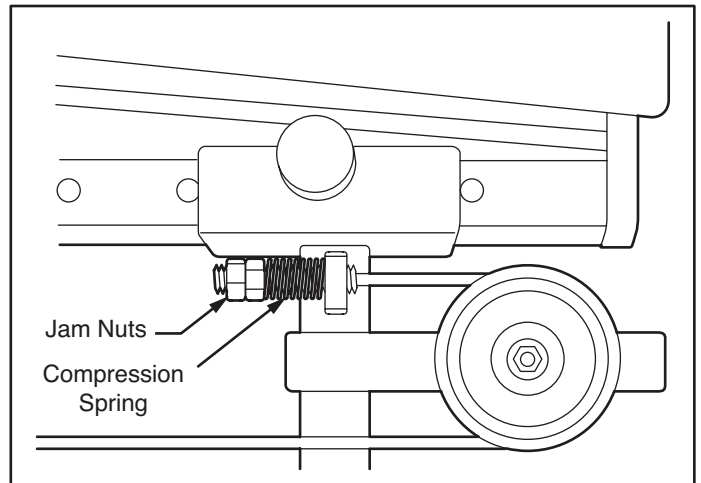

Figure 9b. Redundant Cam Termination With Spring

structural integrity of the cables. The concept of dormant standby redundancy captures the full potential of the cables which fail in situ without compromising safety. This leads to a new paradigm which significantly prolongs the cable replacement intervals, lowers costs, conserves resources, and reduces dependence on operator skills and diligence.

## REFERENCES

- [1] Juran, J.M. and F.M. Gryna, *Juran's Quality Control Handbook*, 4th ed, McGraw-Hill, New York, 1988.
- [2] O'Connor, Patrick D.T., *Practical Reliability Engineering*, 3rd ed, Wiley, New York, 1991. pp. 322-327.
- [3] Barnett, Ralph L., "Doctrine of Manifest Danger," *Triodyne Safety Brief*, Vol. 8, No. 1, September 1992.
- [4] *Reliability Engineering*, ARINC Research Corporation, Prentice-Hall, Inc., Englewood Cliffs, NJ, 1964, p. 199.
- [5] Greene, A.E. and A.J. Bourne, *Reliability Technology*, Systems Reliability Service, U.K. Atomic Energy Authority, Wiley-Interscience, John Wiley & Sons, Ltd., 1972, p. 301.
- [6] "American National Standard for Construction and Demolition Operations – Requirements for Safety Belts, Harnesses, Lanyards and Lifelines for Construction and



Demolition Use,” ANSI A10.14-1991, American National Standards Institute, New York, 1991, p. 8.

[7] <http://idioms.thefreedictionary.com/>, Cambridge International Dictionary of Idioms and the Cambridge Dictionary of American Idioms.



Figure 10a. Idler Tensioning of Standby Cable



Figure 10b. Lower End Connectors