

# **SAFETY OF FITNESS EQUIPMENT CABLES**

**By**

**Ralph L. Barnett<sup>1</sup>**

## **Abstract**

There is a family of exercise machines that provides a manual workout task requiring the user to push or pull against a resistance provided by a stack of weight plates. The weight system is usually linked with a single cable to a gripping or user interface device to produce a constant resistance. A fracture of the tensioned cable along its length or at its end connectors causes a sudden acceleration of the grip or other interface device driven by the operator's push or pull. The sudden loss of resistance often results in an exerciser pulling a heavy bar into his or her face. Because falling weights, accelerating grips and rapidly unloading muscles are all hazardous, manufacturers of exercise machines want to maintain the structural integrity of the cables. To accomplish this, manufacturers usually recommend "scheduled servicing" of their cables. This Preventive Maintenance (PM) strategy is frustrated by nylon sheathing that hides the cable failures. Further, the swedged or silver soldered connectors often fail covertly by internal fatigue fractures. A more effective PM strategy has been adopted by many manufacturers called "Scheduled Replacement"; they advocate annual cable replacement. Here the nemeses are sloth and greed, best expressed by the philosophy, "if it ain't broke, don't fix it." As a first consideration of fault tolerant design, a redundant duplication of the cable system was added to a fitness machine; this is called "active redundancy." This paper demonstrates the inadequacy of active redundancy for eliminating the catastrophic failure mode. Instead, the adoption of a "dormant/standby" redundancy is shown to provide the requisite safety. The proposed system not only eliminates the "fail-to-danger" mode, it provides the most economical use of the cable in the sense that it never discards a cable until its life is exhausted.

## **I. Introduction**

Hanging weights are generally used to provide a constant resistance over the full pulling range on fitness equipment. These weights are usually suspended by a cable mechanism that transfers a selected gravity load to various portions of a human body through handles or foot pedals. This is illustrated by the stripped down fitness machine shown in Figure 1. Manufacturers typically use an aircraft cable (seven strands with 19 wires per strand) that is 3/16 in diameter and covered in a nylon sheath. This highly redundant wire rope is composed of 133 wires; it uses end connectors that are usually swedged and/or silver soldered.

---

<sup>1</sup> Professor, Mechanical & Aerospace Engineering, Illinois Institute of Technology, Chicago, IL;  
Chairman, Triodyne Inc., Northbrook, IL

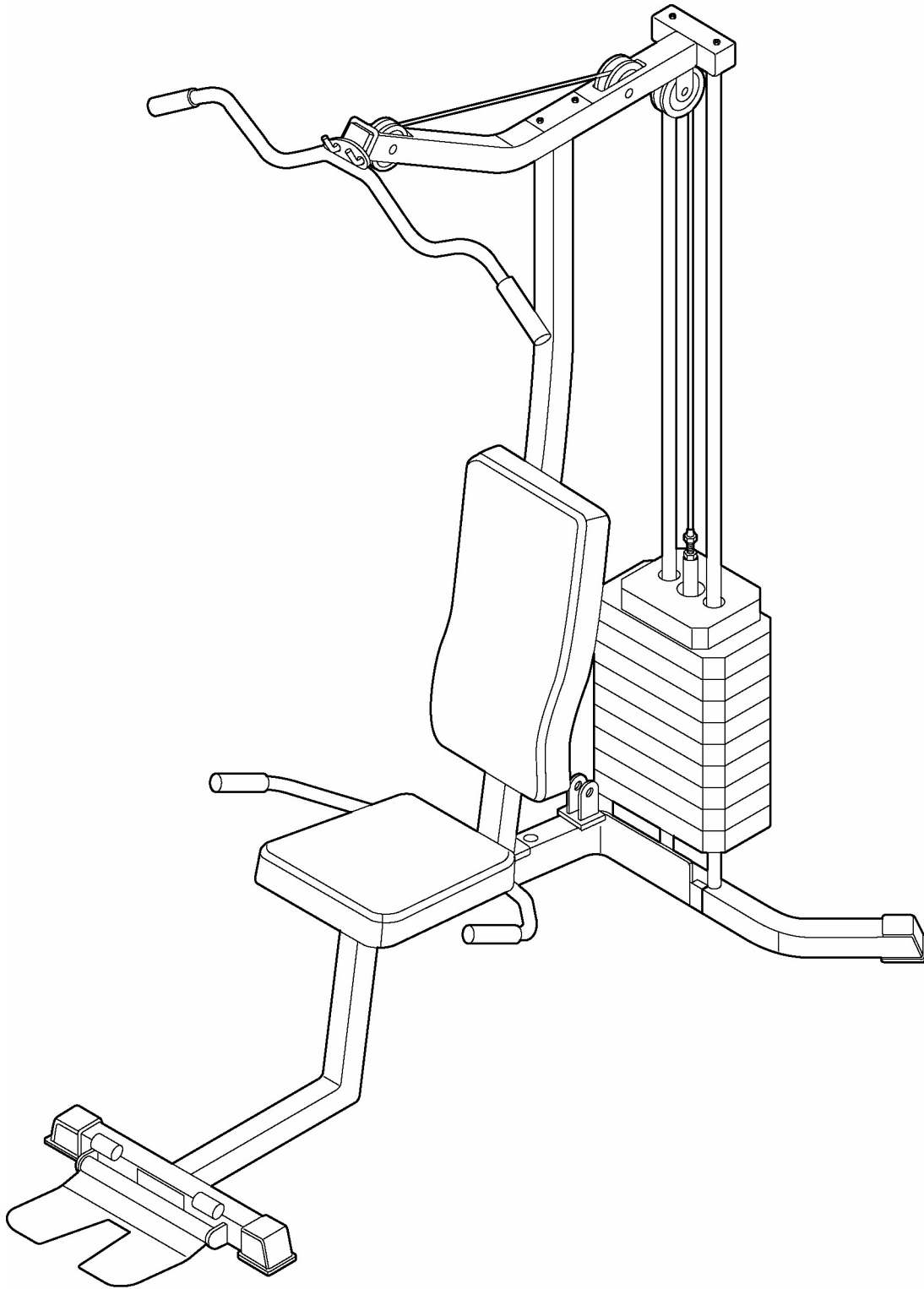

Figure 1a - Fitness Machine

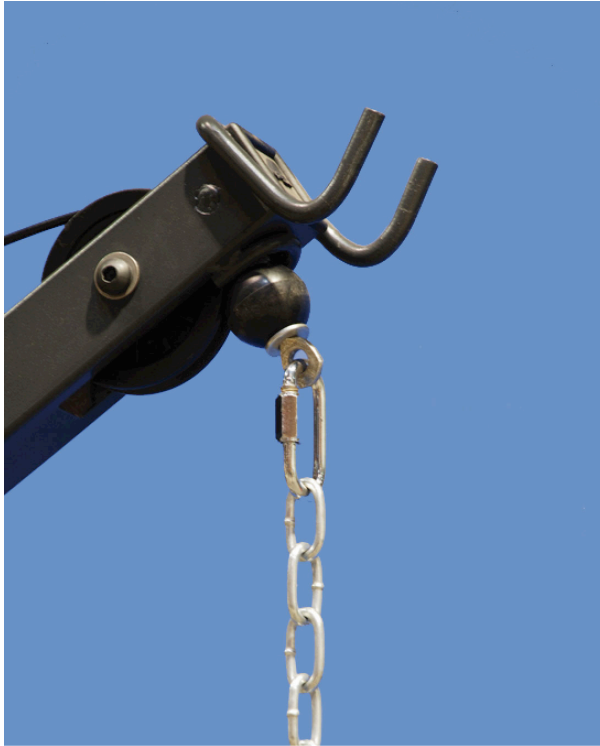

Figure 1b - Upper Termination

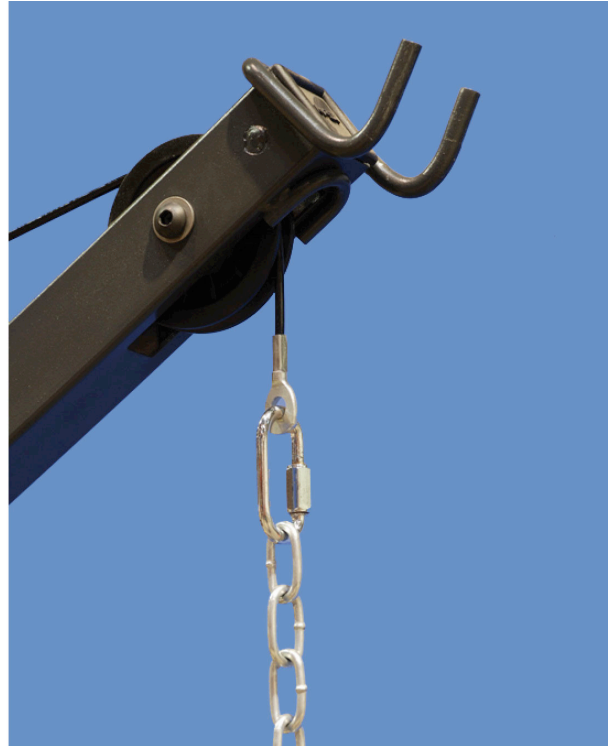

Figure 1c - Upper Termination



Figure 1d - Lower Termination



Figure 1e - Lower Termination

Fitness equipment manufacturers generally advocate preventive maintenance (PM) techniques for maintaining the structural integrity of the cables. Preventive maintenance is defined as actions performed in an attempt to retain an item in a specified condition by providing systematic inspection, detection and prevention of incipient failure by repairing or replacing it. This concept must be contrasted with corrective maintenance which restores an item to a specified condition after it has failed. The two principal PM techniques are *scheduled servicing* and *scheduled replacement* [Ref. 1, 2].

#### Scheduled Servicing:

Scheduled servicing is comprised of scheduled maintenance strategies which reveal incipient failures of items for the purpose of preventing system failures. Various servicing protocols are involved:

- a) Inspection – detection of self-revealing deteriorating conditions of items composing the system.
- b) Non-destructive testing – a body of testing techniques and methods which will not compromise the item tested.
- c) Cleaning
- d) Lubrication
- e) Calibration
- f) Adjustment
- g) Repair (if required)

In 2001, various representatives of the fitness industry published the following recommendations for maintaining cables:

- **Body Master:** All belts and/or cables on all machines must be carefully inspected on a daily basis for any signs of wear, fraying, de-lamination and/or stretching. Replace worn or damaged belts (cables) immediately.
- **Pyramid:** Inspect cable wear (weekly).

- Bally Total Fitness: Inspect cables daily. Replace at first signs of wear.

These three recommendations precisely reflect the PM strategy called Scheduled Servicing. It is very effective for identifying damaged sheathing; on the other hand, it is an impoverished procedure for identifying the onset of fatigue failure.

Fatigue of wire rope manifests itself by successive failures of the constituent wires which form wire fractures – often called “fish hooks” – on the cable surface. Wire rope is a highly redundant tension member that communicates its compromised structural integrity before it fully separates [Ref. 3]. Unfortunately, the nylon sheathing that covers most fitness machine cables hides most wire failures. Furthermore, wire rope failure may occur inside of the end fasteners where no visual feedback is available. The author has investigated such internal fatigue failure on cable showing no other signs of distress.

Scheduled Replacement:

Scheduled replacement involves the replacement of parts at pre-determined times before failure. When the onset of failure of an item cannot be determined, scheduled replacement is the only PM strategy available. Reliability analysis techniques are required to develop replacement schedules that will minimize the number of items which fail. On the other hand, inefficient replacement or maintenance schedules may be adopted through trial and error or anecdotal observations.

The author’s survey of ten fitness organizations in 2001 uncovered the following additional guidelines for cable maintenance:

- Icarian: Replace cables annually.
- Cybex: Replace all cables at least annually.
- Bodymaster: All belts (cables) must be replaced every two years.
- Bally Total Fitness: All cables shall be changed annually or sooner as needed.

Observe that the above cited guidelines require cable replacement regardless of the condition of the wire rope. This is precisely the PM policy of Scheduled Replacement. Every one of the ten manufacturers in our small study required immediate cable replacement after wear was detected; but most did not specify replacement when no damage was detected.

Keeping track of the age of fitness machine cables requires discipline. Throwing away one-year-old cables with no apparent damage goes against the grain of frugality and resource conservation. “Changing out” cables that are inspected daily is work. Many sized new cables must be ordered and inventoried, and operations must be interrupted while new cables are installed. It is easier to ignore scheduled replacement and replace only broken cables or ones with compromised appearance.

The first remediation technique, Scheduled Servicing, is part of the Doctrine of Manifest Danger [Ref. 3] and requires self-revealing deteriorating conditions. The second technique, Scheduled Replacement, requires a cable replacement interval that precludes cable failure. Both systems are active; diligent inspection schedules or regular replacement schedules are critical.

## **II. Fail-Safe Cable Design**

Because PM has not proven to be a satisfactory solution to the problem of cable fracture, it is reasonable to embrace the techniques of fail-safe design. The objective of a fail-safe design is to create a system that sets up a safe condition when a fault occurs. Specifically, failure of a cable should not result in a potential for injury or disaster. Simple redundancy can be achieved by substituting two identical cable systems for the original cable system. This design is called Active Parallel Redundancy [Ref. 4].

### **A. Active redundancy**

Active redundancy is characterized as redundancy wherein all redundant items are operating simultaneously rather than being switched on when needed. The fatigue machine illustrated in Figure 1 was modified by duplicating the original cable system; the resulting redundant machine is shown in Figure 2. Because of symmetry, each of the cables shown in Figure 2b shares the load equally. The resulting lower stress in each cable will extend its life. The conventional argument suggests that when one of the cables fails, the survivor will continue to carry the weights and the failed cable will give notice of the component failure. Upon reflection, this redundant design uses two already redundant nominally identical wire ropes which are woven using a large number of individual wires. The failure of a single wire rope proceeds by a succession of fatigue failures of the wire strands. Eventually, the surviving wires become sufficiently overloaded that the applied tensile stress exceeds the ultimate tensile resistance of the wire strands. When two cables are loaded identically, one would expect the percentage of wire fractures in either cable to be roughly equivalent. Consequently, when one cable breaks, it subjects the other cable, which is on the brink of failing, to twice the applied

load, usually causing it to fail as well. Theoretically, if each cable contained an infinite number of wires, both cables would break simultaneously. Because the number of wires is finite, one cable will always fail first.

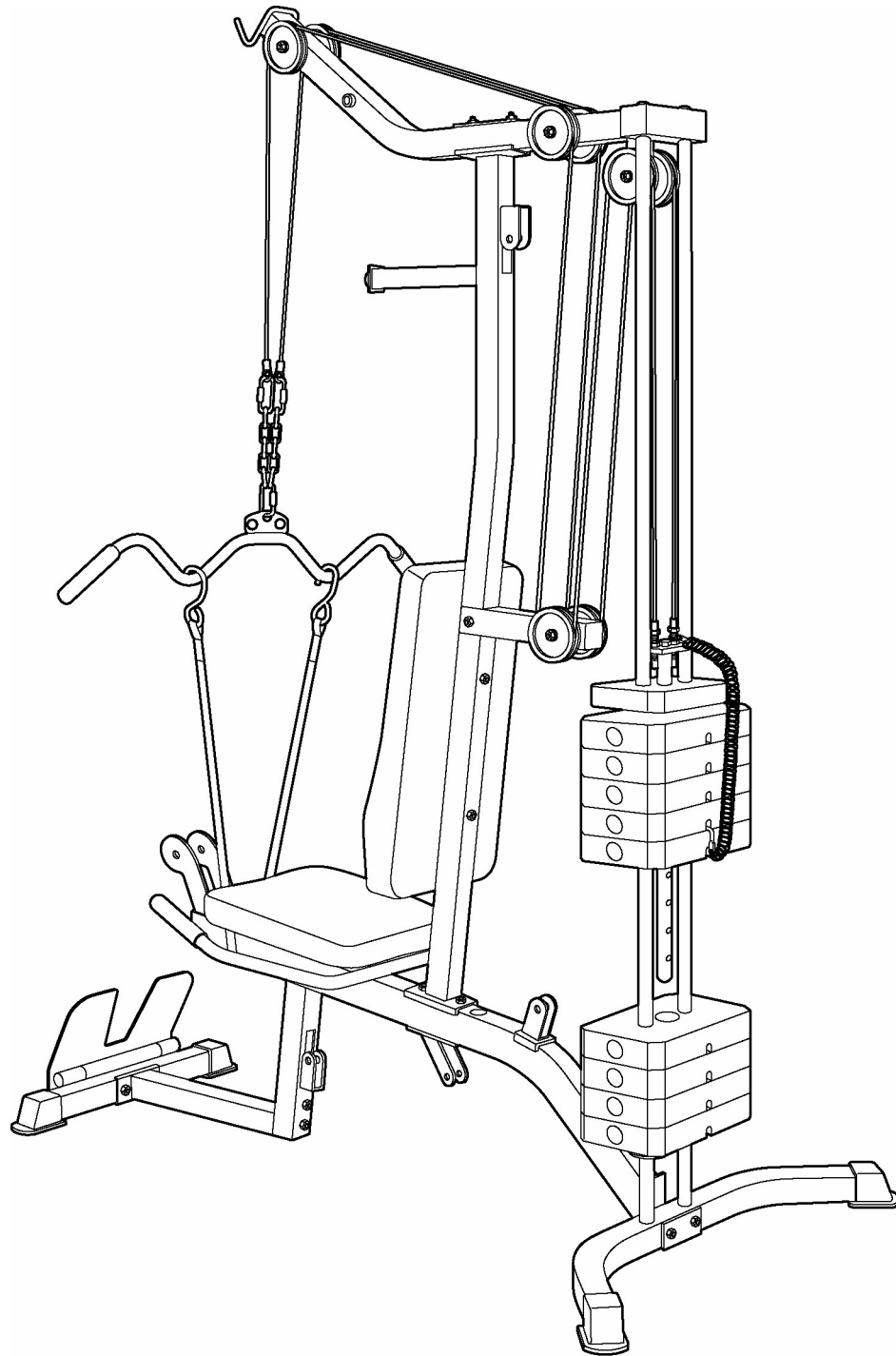

Figure 2a - Fitness Machine (Active Redundant Cable System)

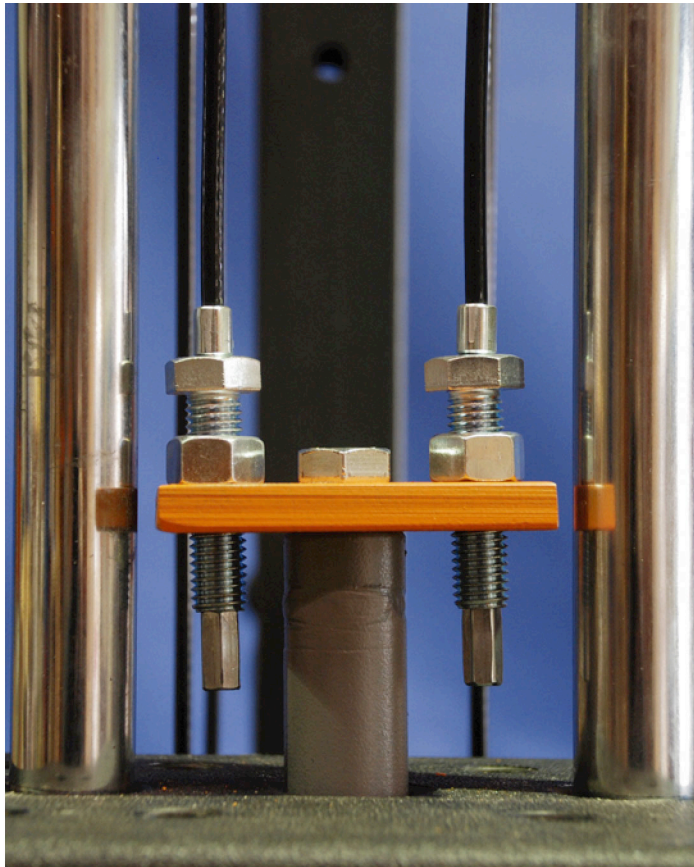

Figure 2b - Stack Connection - Active Redundant Cable System

As a demonstration of active redundancy one of the two new cables shown in Figure 2b was deliberately cut. The surviving cable continued to equilibrate the load; this is conventional behavior. This test shows how active redundancy preserves the structural integrity of the cable system in the face of a random traumatic threat to one of the cables. PM will not provide this protection. As a second demonstration, one section of each cable was reduced from 133 wires to 6 wires as shown in Figure 3a and 3b. Again, one of the cables was deliberately cut and the survivor immediately fractured because the six surviving wires could not support the weight stack as shown in Figure 4.



Figure 3a -  
Left Cable Reduced to 6 Wires



Figure 3b -  
Right Cable Reduced to 6 Wires

Figure 3 - Compromised Cables



Figure 4 - Concurrent Cable Failures

In summary, active redundancy improves the system reliability. The simple act of redundancy will harden the system against traumatic insult to any one of the cables. However, the safety threat of fatigue failure is only prolonged because of the likelihood of dual cable system failure.

B. Dormant Standby Redundancy

Because active parallel redundancy does not eliminate the possibility of cable system failure, a second type of failsafe design is proposed, Dormant Standby Redundancy [Ref. 5]. Dormant standby redundancy is an alternative means of performing a function which is inoperative until needed; switched on upon failure of the primary means of performing the function. An example is the new spare tire in an automobile. The spare tire is not in use until it is substituted for a damaged tire by the automobile's operator. Another example is an ordinary scaffold system which has a new cable life line for each person using the scaffold. If the scaffold collapses, each of the workers is tied off to his own brand new lifeline which is entirely independent of the cables that are holding up the scaffold. The lifelines cannot be used again after a scaffold collapses. The American National Standard, ANSI A10.14-1991, American National Standard for Construction and Demolition Operations – Requirements for Safety Belts, Harnesses, Lanyards and Lifelines for Construction and Demolition Use states the following [Ref. 6]:

*6.1.3 All fall protection systems subjected to impacts caused by a freefall or by testing shall be removed from service and should not be used again.*

As a consequence, scaffold workers are always protected by a new lifeline.

The proposed weight machine cable system is shown in Figure 5a. The dual cables are affixed to the weight stack by the offset plate and compression spring depicted in Figure 5b. Any force applied to the left cable merely shortens the compression spring which limits the left cable loading to about 15 lb. Almost the entire weight stack is lifted by the right cable. If this right cable or its terminations are fractured because of trauma or fatigue, the weight is automatically switched to the “like new” left cable which bottoms out the compression spring as shown in Figure 6 for a different style end connector. Observe that the right cable assumes a serpentine geometry that notifies the operator of a component failure.

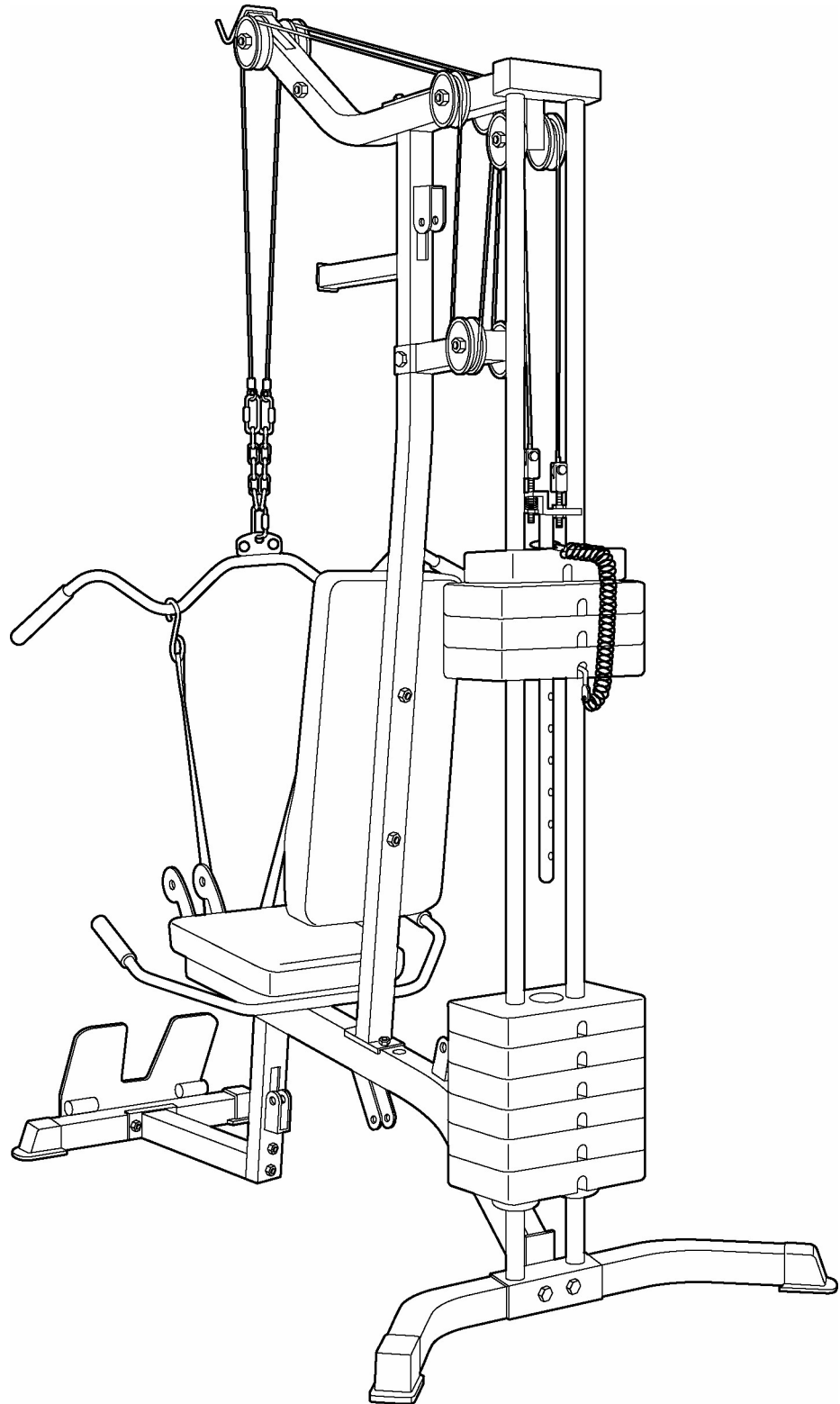

Figure 5a - Dormant Standby Redundant Cable

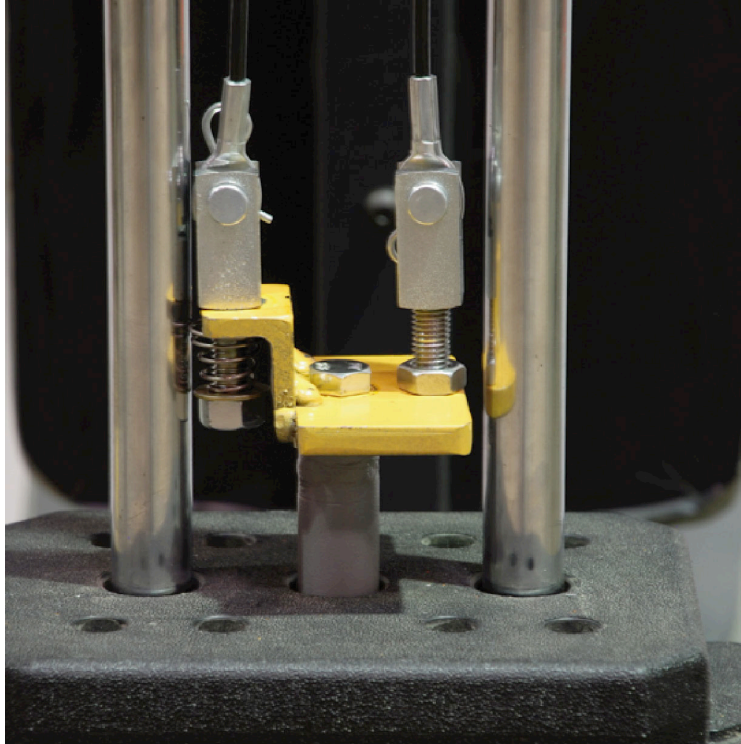

Figure 5b - Off-Set Cable Bracket and Cylindrical Compression Spring

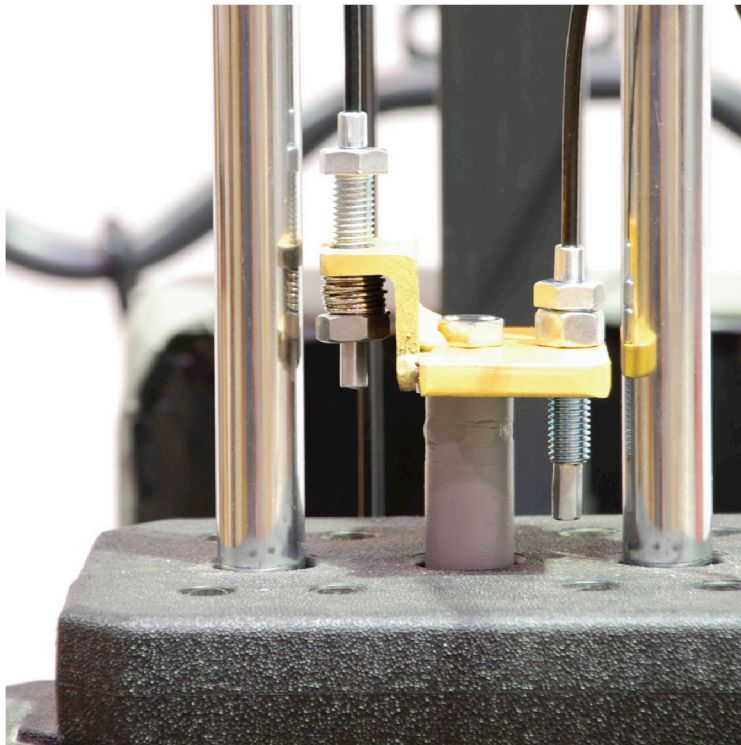

Figure 6 - Compressed Spring on Surviving Cable

When the right cable fractures, its load is transferred to the left cable through a spring. The weight stack falls less than an inch. The broken cable manifests its fracture while an almost new cable continues to support the exercise activity. After the failure, the standby cable is moved to the right position to become the primary load bearing cable. A new cable is substituted for the left cable and becomes the dormant standby member. Observe that the full life of the right cable has been realized, whereas the scheduled replacement PM protocol throws away cables which may have substantial remaining life.

The dormant standby redundant cable system provides a flexible strategy that is easily applied to fit machines with different configurations as shown in Figures 7, 8 and 9. Figure 10 replaces the compression spring with a gravity or spring loaded idler roller which takes up the slack in the dormant standby cable. The cylindrical compression spring can be replaced by a conical spring that provides a shorter compressed height. All of the proposed systems require an offset or phase shift between the parallel cable systems.

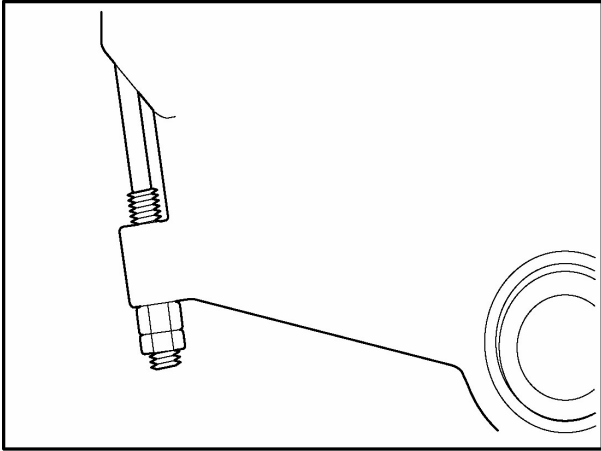

Figure 7a - Primary Cam Termination

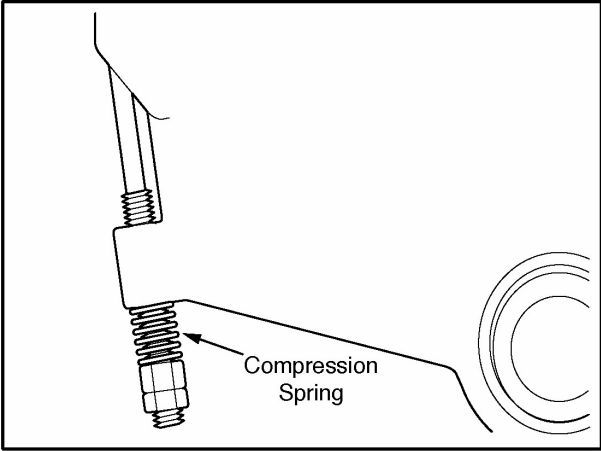

Figure 7b - Redundant Cam Termination With Spring Insert

Figure 7 - Dormant Redundancy Concept - Example 1

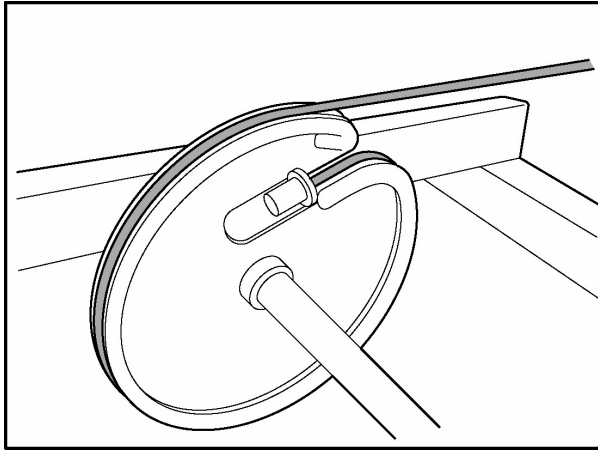

Figure 8a - Primary Cam Termination

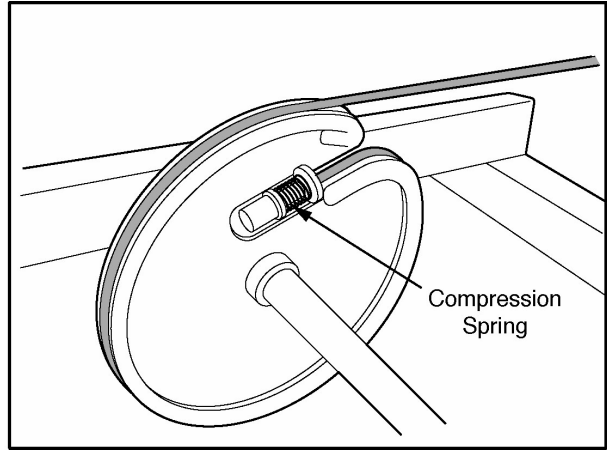

Figure 8b - Redundant Cam Termination With Spring

Figure 8 - Dormant Redundancy Concept - Example 2

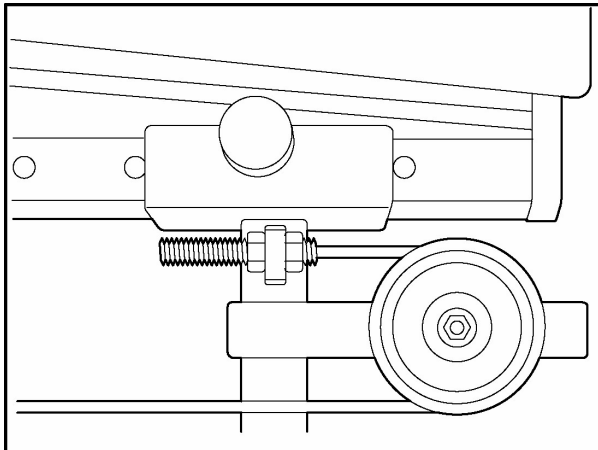

Figure 9a - Primary Cam Termination

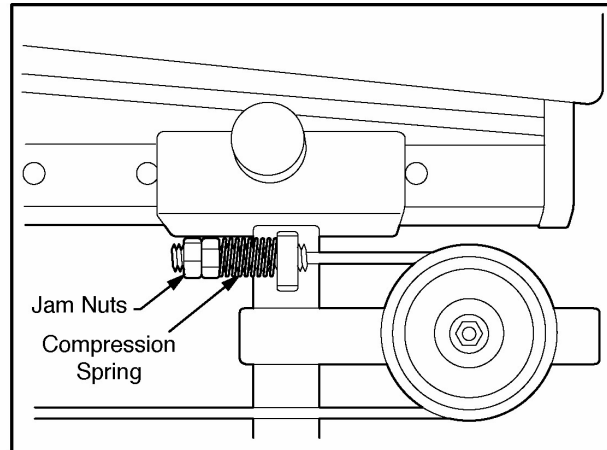

Figure 9b - Redundant Cam Termination With Spring

Figure 9 - Dormant Redundancy Concept - Example 3



Figure 10a - Idler Tensioning of Standby Cable

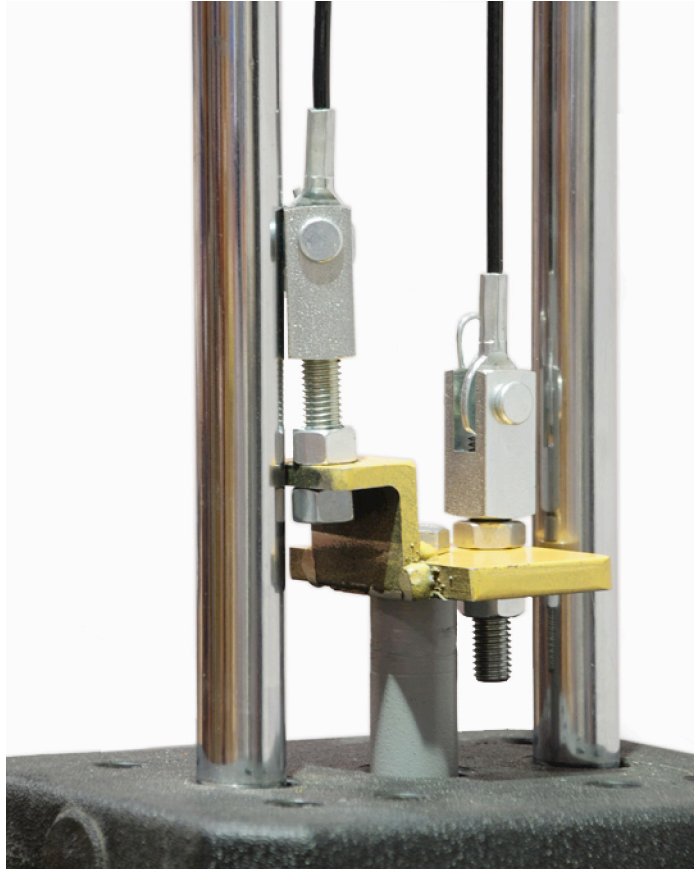

Figure 10b - Lower End Connectors

### III. Conclusions and Observations

- A. The earliest maintenance concept associated with fitness machines was “if it aint broke, don’t fix it” [Ref. 7].
- B. This was followed by a notion that has modern day outcroppings, “if a cable defect manifests itself, replace the cable immediately.” No maintenance intervals are recommended.
- C. Fitness machine manufacturers and health clubs began to embrace the preventive maintenance concept, scheduled servicing. They called for cable inspections to take place in various combinations of daily, weekly, monthly and yearly.

- D. Scheduled servicing is capable of detecting overt or self-revealing faults. It is maintenance intensive and it is subject to human errors associated with subjective observations.
- E. Scheduled servicing will not detect covert faults. Normal cable diagnosis is compromised by the nylon sheathing covering the cables. Connectors can fail by internal fatigue mechanisms that are completely hidden from view.
- F. Today, fitness machine manufacturers and health clubs have added a second PM concept to their cable maintenance program, scheduled replacement. Typically there is an admonition to replace the cables annually regardless of their appearance or condition.
- G. The PM strategies will not protect against failure of cable systems caused by random traumatic assault.
- H. The new PM philosophy which embraces both scheduled servicing and scheduled replacement is not adequate for dealing with the broken cable potential. The combined system is maintenance intensive and requires strict attention to record keeping so that the cable replacements can be made with fidelity. Furthermore, as mentioned above, there are excursions that are traumatic in nature which cannot be protected by the PM concepts. It is reasonably foreseeable that human error will compromise the new PM strategy.
- I. The simplest fault-tolerant concept, *active parallel redundancy*, simply requires the addition of a duplicate of the original cable system. Fail-safe design is very effective for preventing catastrophic failure of the cable system when the cable elements contain random defects or suffer traumatic assaults. On the other hand, when fatigue failure compromises both cables simultaneously the failure of one cable transfers its load to the surviving cable which usually cannot handle the double loading. The cable fracture hazard is not averted.
- J. The application of a fail-safe concept called *dormant standby redundancy* provides a brand new standby cable as a sentinel to keep watch over the original primary load carrying cable that supports the weight plates. Failure of the primary cable by the formation of overt faults, covert faults or trauma, will cause a brand new cable to take over the function of the original load bearing cable system.

- K. The proposed fail-safe design employing dormant standby redundancy provides a total back-up to the original cable system in the event of cable failure.
- L. When the primary load bearing cable fractures, it assumes a serpentine profile which wraps around the fitness machine to inform the user of a component failure. The standby cable, which is essentially brand new, will completely support the weight stack under any weight use profile.
- M. The subjectiveness and human error associated with the PM strategies is almost completely eliminated with the use of the proposed fail-safe system.
- N. The original cable may be used for periods much longer than one year. The cable life will be determined either by overt failures of the nylon coating which can cause excessive wear in the pulleys or upon fracture of the cable system by covert faults or external trauma.
- O. Upon failure of the primary cable, the standby cable takes its place and a new cable is substituted for the standby cable. The full life of cables is utilized; the interval between cable replacements is greatly extended.
- P. The proposed fail-safe design concept is extremely flexible in its application.

## References

- [1] Juran, J.M. and F.M. Gryna, Juran's Quality Control Handbook, 4<sup>th</sup> ed, McGraw-Hill, New York, 1988.
- [2] O'Connor, Patrick D.T., Practical Reliability Engineering, 2<sup>nd</sup> ed, Wiley, New York, 1991. pp. 214-127.
- [3] Barnett, Ralph L., "Doctrine of Manifest Danger," Triodyne Safety Brief, Vol. 8, No. 1, September 1992.
- [4] Reliability Engineering, ARINC Research Corporation, Prentice-Hall, Inc., Englewood Cliffs, NJ, p. 199.
- [5] Greene, A.E. and A.J. Bourne, Reliability Technology, Systems Reliability Service, U.K. Atomic Energy Authority, Wiley-Interscience, John Wiley & Sons, Ltd., 1972, p. 301.
- [6] "American National Standard for Construction and Demolition Operations – Requirements for Safety Belts, Harnesses, Lanyards and Lifelines for Construction and Demolition Use," ANSI A10.14-1991, American National Standards Institute, New York, 1991, p. 301.
- [7] <http://idioms.thefreedictionary.com/>, Cambridge International Dictionary of Idioms and the Cambridge Dictionary of American Idioms.