



Triodyne Inc.

3054 N. Lake Terrace Glenview, IL 60026
847-677-4730, Fax 847-647-2047
infoserv@triodyne.com

Safety Brief Vol. 30 No. 3

Anti-Evisceration Rings – Proof of Concept

Ralph L. Barnett
Professor, Mechanical and
Aerospace Engineering

ABSTRACT

Domed suction entrapment covers (grates) are generally mounted on cylindrical sumps or frames (mud rings) that are permanently installed in the bottoms or sidewalls of swimming or wading pools. These covers constitute a first-line-of-defense against the danger of evisceration by preventing children from sealing the sumps and drains with their buttock. When the covers are missing, loose, or broken, sealing a sump with their backsides exposes their bowels to dangerous levels of suction that cause disembowelment in a fraction of a second. There is an emerging paradigm shift in the aquatic's industry that calls for equivalent protection for covered and uncovered sumps and frames. Using a simple concept patented by Barnett (2001) [1], the planar circle formed by the inside edge of a sump is replaced by a non-planar edge, e.g., scalloped or castellated. Edge geometry is chosen that will not conform to human body parts to preclude sealing. Testing inexpensive prototypes demonstrated that the proposed anti-evisceration rings reduce the body removal force from 324 lb. to 10 to 17 lb. Further, they lower the maximum pump vacuum from -14.3 psi to -1 to -2 psi.

INTRODUCTION

A. Problem Description

The weight of air produces a pressure of 14.7 psi at sea level. Solid bodies subjected to this uniform pressure develop a hydrostatic stress state, i.e., a homogeneous and isotropic compressive stress state, $\sigma = -14.7$ psi [2]. If a portion of one's body is subjected to suction, say by sucking on an arm, that area effectively develops tensile tractions whose magnitude approach 14.7 psi as a perfect vacuum is approximated. High levels of vacuum leave hickeys on the skin and, if applied to the intestines, produce evisceration.

When a body is submerged in water, it is pressurized by both the weight of air and water as illustrated in Fig. 1a where p

is the absolute pressure and γ is the specific weight of water i.e., the weight per unit volume. When p is measured as pounds per square inch and H is measured in feet, γ may be taken as 0.4333 psi/ft of depth. Table I indicates the water pressure acting on the bottom of various depth pools.

A child's buttock cannot seal a modern drain cover, such as shown in Fig. 2a, because the periphery is filled with passageways that allow water to flow into the sump. On the other hand, when the cover is removed a circular hole is revealed in the bottom of the pool that a child can sit on. The inside edge of the circular hole formed by the top of a sump or frame (mud ring) is easily sealed by a child's backside as illustrated by the spheres in Fig. 3.

B. Entrapment Avoidance Systems

When a child's bottom seals a drain, the differential pressure between the pool-side and the drain-side will determine the onset of evisceration. Figure 1 characterizes a number of candidate entrapment avoidance systems that are currently available for limiting this differential pressure.

Dual Drains

As illustrated in Fig. 1b, parallel plumbing of multiple drains in an unblockable array allow water to flow into the pump in the face of complete blockage of any one drain. The differential pressure at the blockage has been found to be de minimis; it will not lead to disembowelment.

Unblockable Drains and Sumps

When drain covers or sumps, as depicted in Fig. 1c, cannot be shadowed by an 18" x 23" body, a child cannot affect a seal in the suction system. Water flowing around the child's body precludes the development of significant differential pressures that could cause evisceration.

$p = 1 \text{ atmosphere} = 14.7 \text{ psi} = 30 \text{ in. Mercury} = 34 \text{ ft. water}$

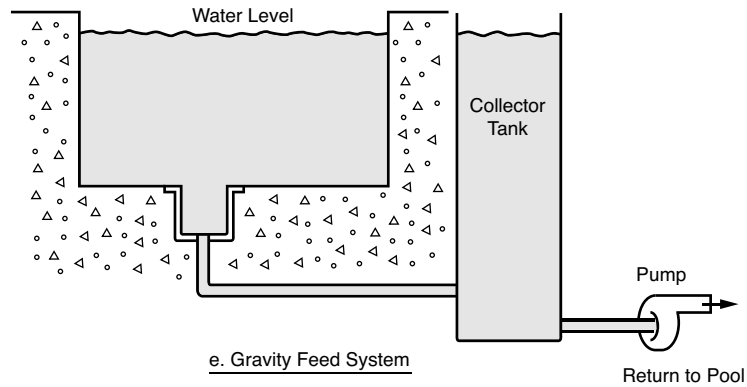
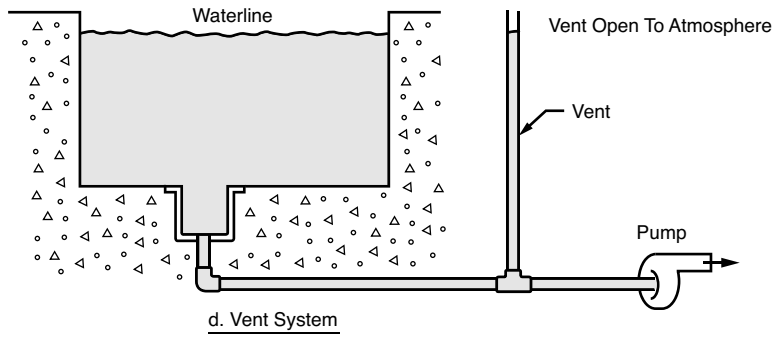
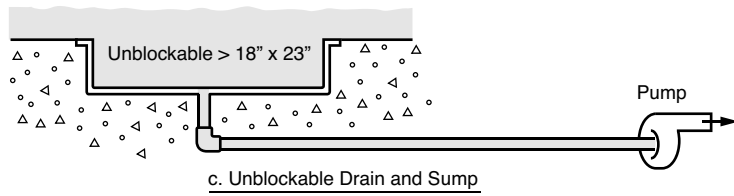
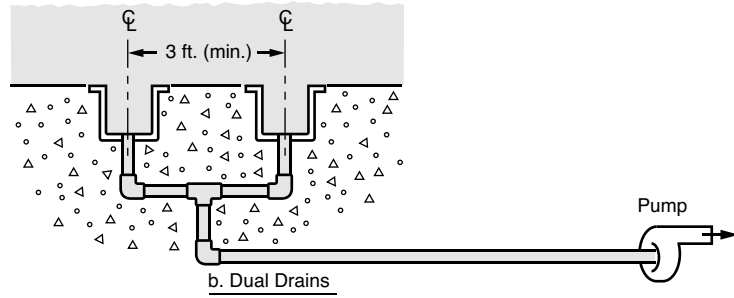
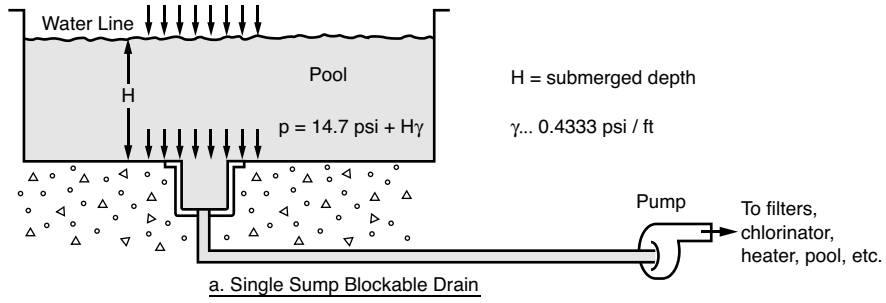


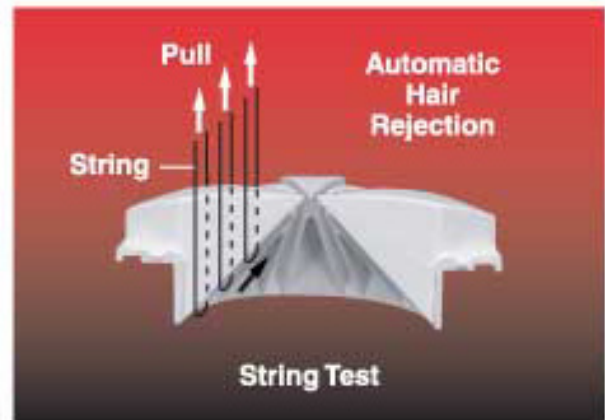
Figure 1. Entrapment Avoidance Systems

Table I. Water Depth v. Water Pressure

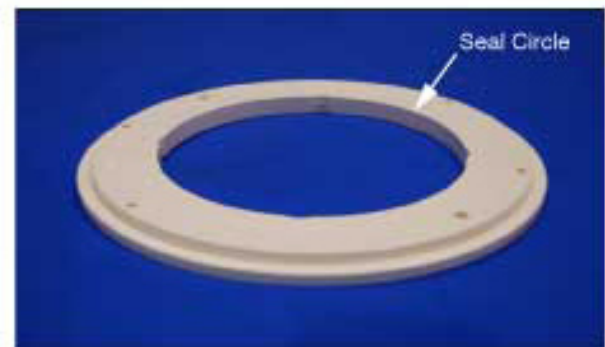
Water Depth H... ft	Water Pressure psi
1 ft	0.43 psi
1.5 ft	0.65 psi
2 ft	0.87 psi
3 ft	1.30 psi
4 ft	1.73 psi
5 ft	2.17 psi
6 ft	2.60 psi
8 ft	3.47 psi
10 ft	4.33 psi
12 ft	5.20 psi



a) Anti-Hair Snare Plus® Cover



b) Cross Section



c) Typical Frame (Mud Ring)

Vent System

A simple vent system is shown in Fig. 1d where the water level in the vent tube reflects the pool's waterline. Should the outlet in the main drain become obstructed, the pump begins to draw down the water in the vent tube until air is introduced into the pump which loses its prim (suction is broken). The effectiveness of the simple vent system for preventing evisceration has not been established; however, a variation on the design called "Hydraulically Balanced Vent System" provides a very small differential pressure that will certainly eliminate evisceration hazards. [3]

Gravity Feed Systems

The gravity feed system depicted in Fig. 1e indicates that the pump is not directly connected to the pool. As water is pumped out of the collection or surge tank, gravity refills it with water drawn from the pool seeking pressure equalization. Suction at the main drain is normally quite modest which precludes body entrapment and evisceration. However, if somehow the entire collector tank were evacuated the magnitude of the vacuum levels would be limited to the pressures tabulated in Table I. It must be emphasized that the water pressure developed in deep pools may very well give rise to pressure differentials that will cause disembowelment.

DESIGN CONCEPTS

Assume that the seal circle defined in Fig. 3 is disrupted by scallops or castellations such as shown in Figs. 4 and 5 respectively. If the undulations are sufficiently aggressive, bathers cannot affect a seal with their backsides. The resulting flow of water passing

Figure 2. Typical Suction Outlet Cover

into the sump, if sufficiently large, will suppress the differential pressure acting on the bather to a safe level.

Figure 5a illustrates an open groove (crenel) castellation ring that has been permanently retrofitted to a sump by adhesive and possibly screws. In this coverless state the inside edge cannot

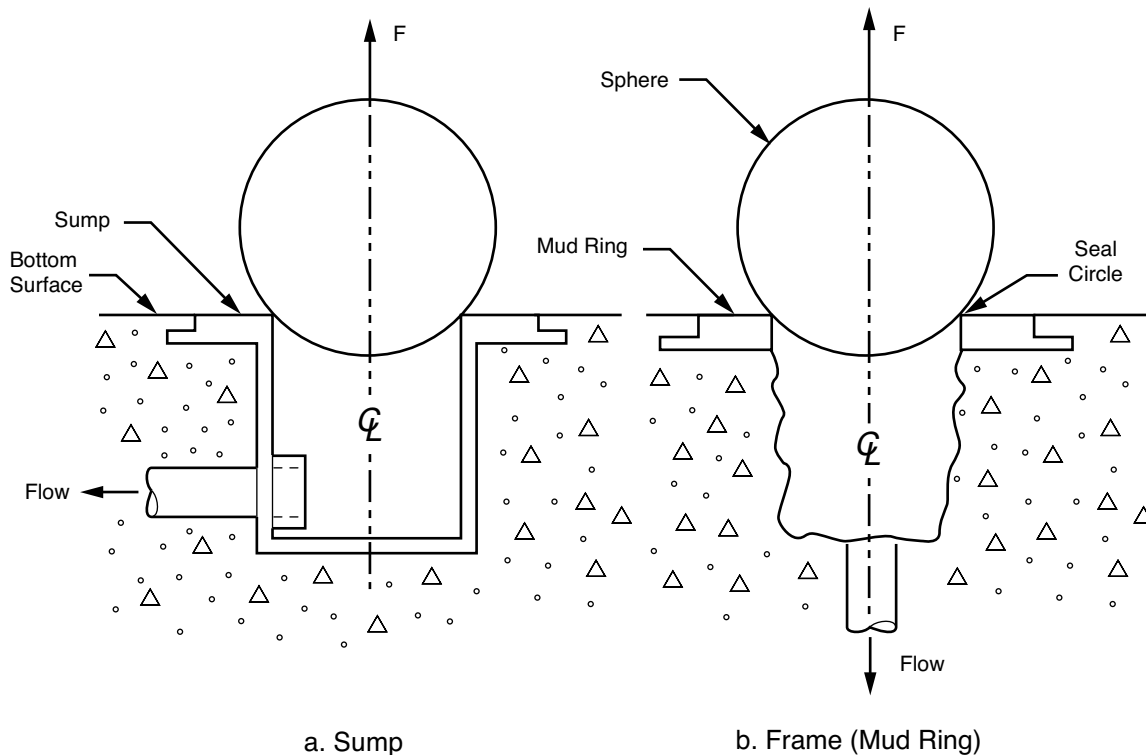


Figure 3. Sphere Sealing Both Sump and Fume

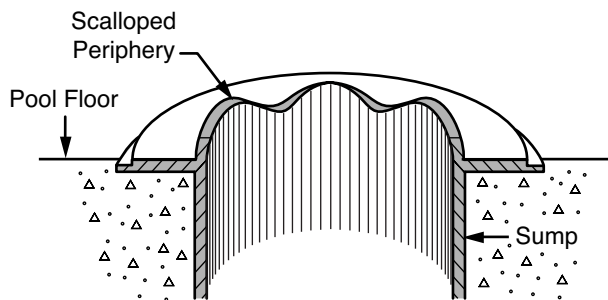


Figure 4. Scalloped Sump Without Cover

be sealed by a bather's backside; the inside windows become orifices with a total flow area of almost 7 in². Maximizing the orifices minimizes the differential pressure acting on the bather. If children lay their bodies on top of the sump, it is extremely difficult to block the open grooves. This, of course, mitigates the risk of body entrapment.

A castellated frame is illustrated in Fig. 6a. When used with the skirted Anti-Hair Snare cover shown in Fig. 2a, the frame is installed with the frame protruding above the bottom of the pool as depicted in Fig. 6b. Observe in Fig. 6c that the skirt of the Anti-Hair Snare cover blocks the open crenel so that hair cannot be entrained through this passageway when the cover is in place. The open configuration increases flow in the crenel and makes it very difficult for children to seal the frame even without a cover.

Conventional covers are skirtless; here, the frame is buried in the concrete (gunite) surface so that the merlons are flush with the pool bottom (Fig. 6d). With the cover in place hair cannot enter the sump area through the frame (Fig. 6e). Flow into the crenels is more restricted with the closed circumference and it is easier for a child to shadow the frame compared to the open crenel configuration. There are six pairs of merlons to accommodate the cover fasteners.

A retro-fittable anti-evisceration ring is shown in Fig. 7a which can be permanently affixed to most cylindrical sumps. A Hayward sump (Model: SP1052AV) is illustrated in Fig. 7b; it is shown with a Hayward cover (Model: SP1018) in Fig. 7c. The Hayward sump has been retrofitted with an anti-evisceration ring in Fig. 7d. The retrofitted sump is depicted in Fig. 7e with the Hayward cover in place. As illustrated in Fig. 8, the ring geometry allows the cover to be screwed into the original bosses molded into the sump; albeit with screws that are 1/2 in. longer than the original 316 stainless steel screws. For most sumps the covers are fastened directly into the original boss; however, if necessary the merlons can be drilled to fit a cover. To satisfy the American National Standard for Suction Fittings for Use in Swimming Pools, Wading Pools, Spas, and Hot Tubs, ANSI/APSP-16 2011, Sec. 2.1.4 [4], the combined height of the cover and safety ring must not exceed 2 in.

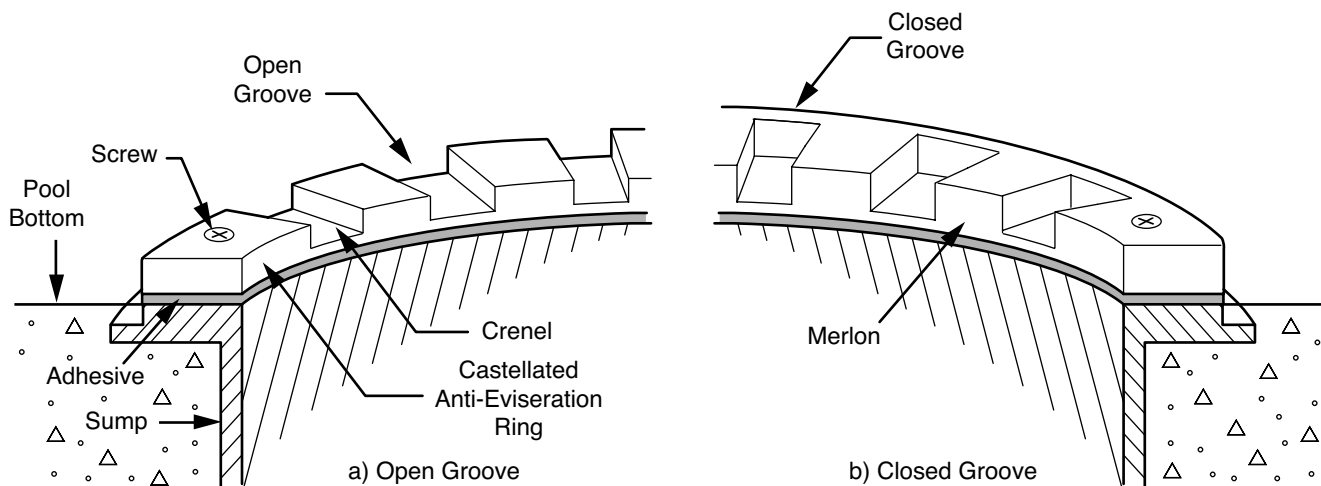


Figure 5. Castellated Safety Ring - Permanent

As a final observation, the retrofit anti-evisceration ring may be modestly increased or decreased in diameter by making a radial saw cut through a section such as shown in Fig. 7a.

Aqua Star Pool Products [5], has developed a castellated sump that supports a conventional skirtless cover inside a ring of castellations that is permanently attached to the sump. This design is shown in Fig. 9 with and without the suction outlet cover; evisceration is eliminated in both configurations. Furthermore, body entrapment is mitigated by the castellations that resist sealing especially by children. Aqua Star uses a vented riser ring that was introduced into various Aqua Star suction outlet models to bring them into compliance with the federal Virginia Graham Baker Act [6].

The Aqua Star cover, Model: LP8AV-XXX, represents a standard strainer-type design that resists hair entanglement by setting a sufficiently low flow rate. By contrast, the Anti-Hair Snare Plus[®] cover, [7], sheds entrapped hair using the sloped cantilevers depicted in Fig. 2b. The Anti-Hare Snare cover may be seated in the frames shown in Figs. 2c, 6a and 7a; in situ the cover appears as shown in Figs. 10a, b, c respectively. In each case the cover extends no greater than 2 in. above the surface as required by aquatic standards.

PROOF OF CONCEPT

With reference to Fig. 3, the maximum removal force F_S required to lift a sphere from a conventional sump or frame can be compared to the maximum removal force F_C associated with an equivalent diameter castellated surface. If the area enclosed by the seal circle is given by A , the effective removal pressure is $P_S = F_S/A$. High removal pressures will eviscerate, low pressures will not. The effort required to lift a child from the sump is related to the removal forces F_S and F_C .

Release forces were determined using the test set-up illustrated in Fig. 11 which consists of the following components:

Pump:

STA-RITE Dura-Glass II Centrifugal Pump, Model No. P4RA6G-188L, 2 hp, 3450 rpm.

Filter:

Jacuzzi Sherlock, Model: SHER120

Lift System:

Compact Acme Screw Jack with Inverted-Style Flange and Mounting Plate; MFG. Joyce/Dayton Corp; McMaster-Carr Part Number: 5945k63

Load Cell:

Mark-10 Corporation, Smart Force and Torque Sensor, Model: Mark-10 MR01-1000, Calibration: 12-16-11

Reader:

Mark-10 Corporation, Digital Force/Torque Indicator; Model: Mark 10 3mi; Calibration: 12-16-11

Sump:

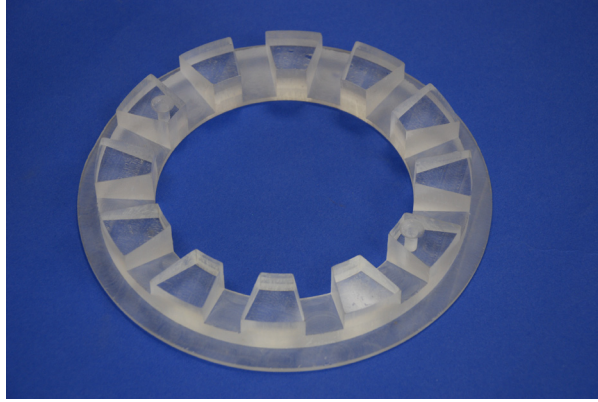
Hayward Pool Products Inc., Model: SP1052AV

Tank:

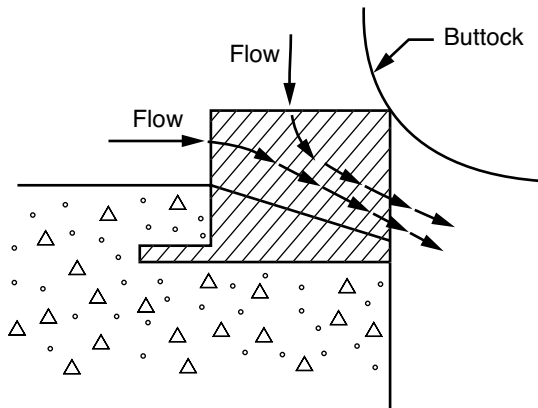
Size: W 28.5", H 33", L 53.75" (Inside), Single Drain Plumbing, Water Height: 18", Pipe Diameter I.D. = 2" Digital Pressure Gauge, Sealed Unit Parts Co., Inc., Model DPG1000/100

Carbon Steel Floats:

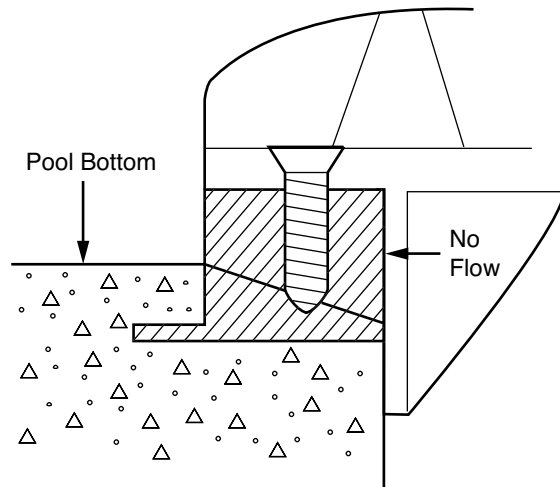
Hollow Spherical Cold-Rolled



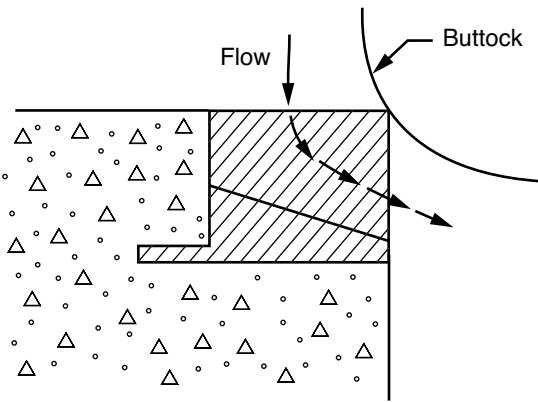
a) Castellated Frame



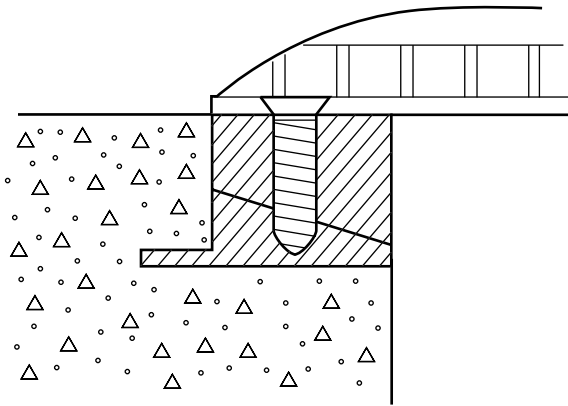
b) Frame Protruding From Surface



c) Frame with Anti-Hair Snare Cover

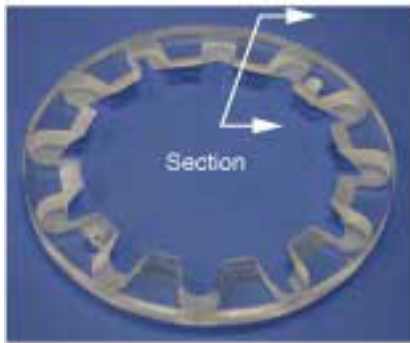


d) Frame Flush With Surface



e) Frame with Conventional Cover

Figure 6. Anti-Eviseration Ring Castellated Frame



Isometric



Plan View

a) Retrofit Castellated Ring



b) Sump - Hayward



c) Sump with Cover



d) Retrofitted Anti-Eviseration Ring



e) Retrofitted Sump With Cover

Figure 7. Sump Retrofitted With An Anti-Eviseration Ring

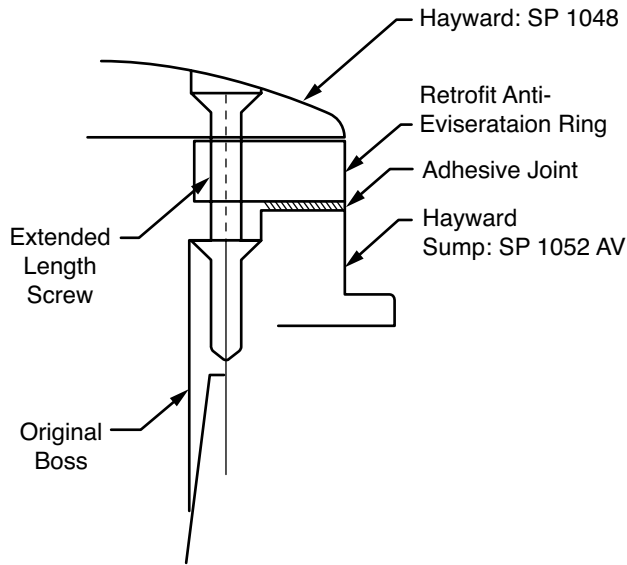


Figure 8. Cover Fastener Detail

Diameter O.D.	Connection Thread	Guage	McMaster-Carr Order Number
6 in.	1/4 NPT	20	46595K21
7 in.	3/8 NPT	20	46595K25
8 in.	3/8 NPT	18	46595K28

The testing program began by establishing the submerged weights of the steel test floats; the weights are presented in Table II. The weights provide the correction factors required for the release tests conducted on conventional frames, castellated frames, retrofit castellated ring, and the Aqua Star sump.

The release force F_s was measured on a conventional frame with an ID = 5.375 in.; it was perfectly sealed by a 6 in. diameter sphere. The data tabulated in Table III indicates that the sealed release force $F_s = 322.9$ lb. with almost no variation; the coefficient of variation is only 0.44%. With a perfect vacuum, -14.7 psi, the frame would resist 333.6 lb.; consequently, the pump has an efficiency of $(322.9/333.6) = 96.8\%$. The actual vacuum that could act on a child's backside is $p = -14.23$ psi. In summary, a missing cover could expose a child to an evisceration vacuum of -14.23 psi and a body entrapment force of 322.9 lb.

A 12-gap castellated frame with an ID = 5.375 in. was blocked with spheres that were 6", 7", and 8" in outside diameter. Table IV indicates that the average release force F_c is between 8.2 and 10.4 lb. with a vacuum measured as $p = -1$ psi. The castellated frame reduced the sealed hold-down force from 323 lb. to approximately 9 lb. making escape easy for a child. Furthermore, disembowelment cannot occur at vacuum levels of -1 to -2 psi (industry consensus not science). No wedging is anticipated because the slots are 3/4 in. wide and do not taper.



a) Sump Without Cover



b) Sump With Cover

Figure 9. Aqua Star Sump Model 8SBxxx

A closed groove 12-gap retrofit anti-evisceration ring with an ID = 5.375 in. was tested with blocking spheres of 6", 7" and 8" diameter; the tabulated release forces F_c are found in Table V. The release forces are higher than the castellated frame forces because the crenels (slots) are more restricted; however, the hold-down forces are less than 15 lb. with a measured vacuum that is -1 to -2 psi. The test trials show almost no deviations.

In spite of the fact that the Aqua Star Vented Riser Ring was not designed to resist evisceration or body entrapment with its cover removed, its castellations turn out to be children friendly. Table VI displays the release forces F_s acting on blocking spheres



a) Standard Frame



b) Castellated Frame



c) Retrofit Castellated Ring

Figure 10. Frame and Sump Mounted Anti-Hair Snare Plus® Cover

that are 7" and 8" in diameter; the average hold-down forces are 25.6 lb. and 16.3 lb. respectively. Vacuum pressures did not exceed -2 psi. Without the castellations a coverless sump, with its ID = 6.75 in., has a sealed release force $F_s = 526$ lb. Rescuing an entrapped victim cannot be accomplished without removing the vacuum.

CLOSING REMARKS

- A. The 12-gap castellated anti-evisceration rings eliminate disembowelment. Practical ring configurations using 14-gaps and 16-gaps are available that will entertain even smaller vacuums and body entrapment forces.
- B. The outside diameter of the proposed retrofit safety ring is 7 5/8 in. Many of the available sumps are constructed with a recess that supports a 7 5/8 in. cover; it is natural to mount the retrofit ring into this recess. Sometimes an existing recess is slightly smaller or larger than 7 5/8 in. Here, the retrofit ring may be cut at one station to act like a bracelet that can expand or contract to accommodate the recess.
- C. The retrofit anti-evisceration ring has several noteworthy features,
 - Because of the even number of gaps, it is almost always possible to screw the original sump cover to the lugs built into the sump without drilling out the ring.
 - The retrofitted ring should be cemented onto the sump or frame. If additional screws are desirable for integrity or for temporary clamping, the 12 gap ring has generous size castellation that allow drilling away from edges.
 - The castellations are ramped to enlarge the discharge apertures and to help shed any hair strands.
 - The anti-evisceration ring raises the normal cover an additional 1/2 in. above the bottom surface of the pool. This makes it more difficult for adults to seal the drain covers with their bodies.
- D. Children sitting on an uncovered sump with a 12-gap anti-evisceration ring will not be exposed to vacuum levels beyond -2 psi. A 14 gap ring will limit the vacuum to -1 psi. There is a general unconfirmed notion in the aquatic industry that evisceration will not occur at -2 psi.
- E. Both the Aqua Star and the proposed anti-evisceration frames have features that mitigate body entrapment in the face of missing covers.
- F. The author has proposed an anti-limb entrapment insert for the suction outlet pipes that services both field built and manufactured sumps. When the insert is used in conjunction with the anti-evisceration ring, covered and uncovered sumps are almost equivalent. Only body entrapment remains as a suction hazard.

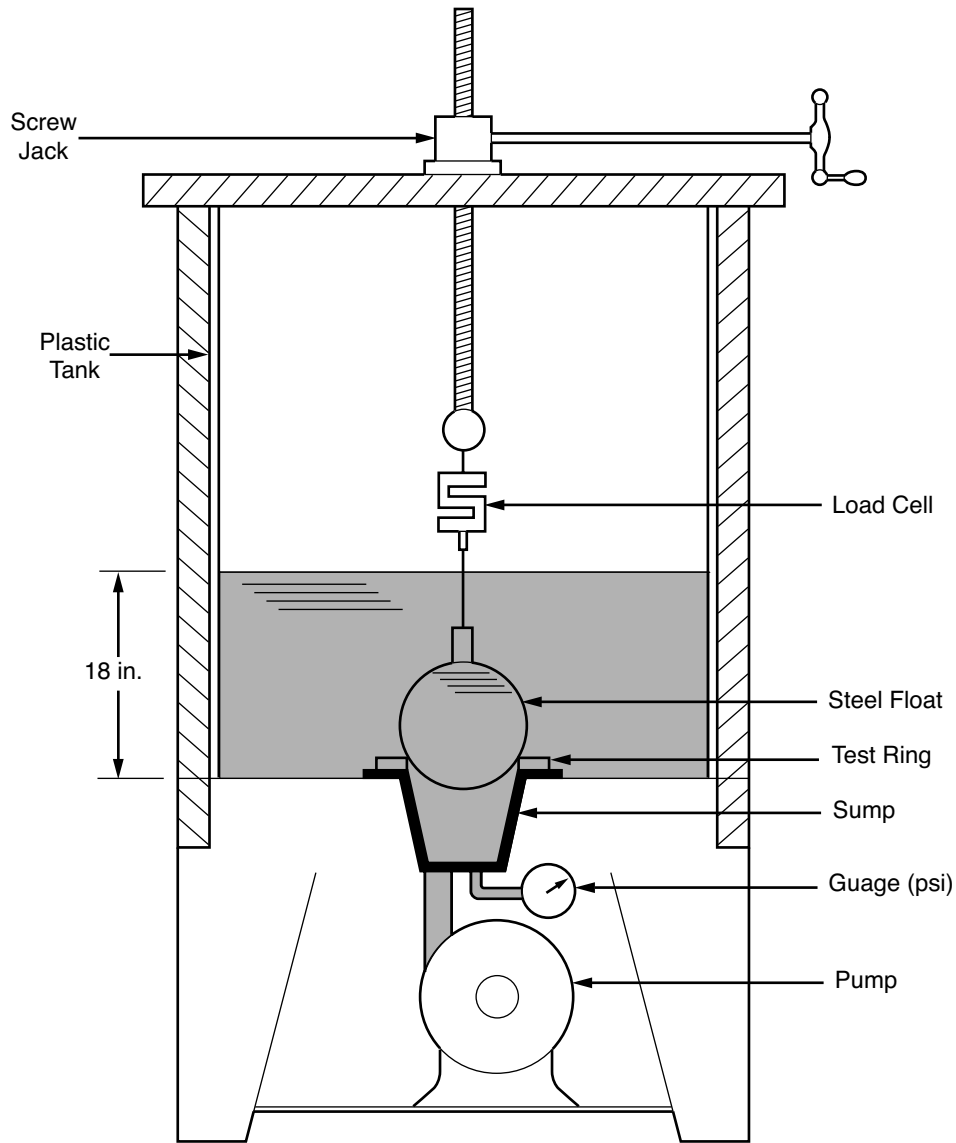
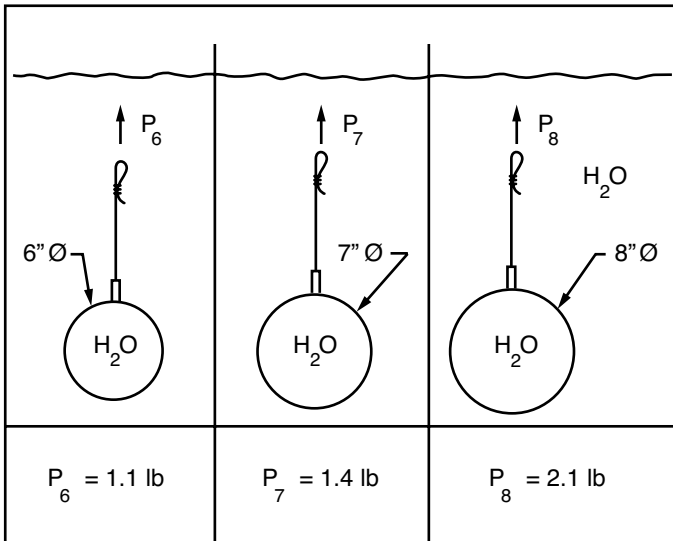


Figure 11. Test Set-Up Removal Forces

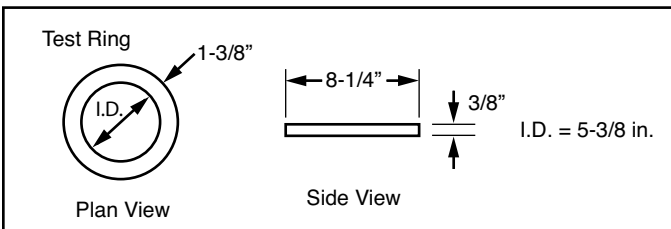
REFERENCES

- [1] Barnett, Ralph L., "Anti-Vacuum Drain Cover," US Patent, No. 6,230,337 B1, May 15, 2001.
- [2] Timoshenko, S. and Goodier, J.N. "Theory of Elasticity," McGraw Hill Book Company, 1951.
- [3] "Guidelines for Entrapment Hazards: Making Pools and Spas Safer," US Consumer Product Safety Commission, March, 2005.
- [4] "American National Standard for Suction Fittings for Use in Swimming Pools, Wading Pools, Spas, and Hot Tubs," ANSI/APSP-16, February 17, 2001.
- [5] "VGB Series, Submerged, Multiple and Single Suction Outlet Instructions," Aqua Star, www.aquastarpoolproducts.com
- [6] Virginia Graeme Baker Pool and Spa Safety Act,
- [7] Barnett, Ralph L. and Poczynok, Peter J., "Anti-Hair Snare Pool Drain Cover," Triodyne Inc. Safety Brief, Volume 18, Number 4, May, 2001.

Table II. Submerged Weights - Steel Float Test Fixtures

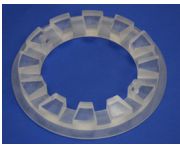


**Table III. Release Force F_s :
Conventional Sealed Sump or Frame**

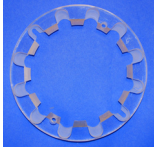


Test	Trial	Release Force (Uncorrected), F_s
	1.	324 lb.
	2.	322 lb.
	3.	326 lb.
	4.	324 lb.
	5.	324 lb.
	Avg.	324 lb.
	Std. Dev.	1.41 lb.
	Corrected Avg.	322.9 lb.
	Vacuum Pressure	-14.23 psi


**Table IV. Release Force F_s :
Castellated Frame (12 gaps)**

			
Trial	Release Force (Uncorrected), F (lb.)		
	6" Sphere	7" Sphere	8" Sphere
1	10	10	11
2	12	10	10
3	11	10	10
4	11	10	10
5	12	10	11
6	12	10	10
7	12	10	10
8	12	10	10
9	11	10	11
10	12	10	10
	Average: 11.5 lb.	Average: 10 lb.	Average: 10.3 lb.
	Std Dev.: 0.707 lb.	Std Dev.: Zero	Std Dev.: 0.483 lb.
	Corr. Avg.: 10.4 lb	Corr. Avg.: 8.6 lb	Corr. Avg.: 8.2 lb.
	Vacuum: -1 to -2 psi	Vacuum: -1 psi	Vacuum: -1 psi

**Table V. Release Force F_c :
Retrofit Anti-Eviseration Ring (12 gaps)**

 I.D. = 5-3/8"			
Trial	Release Force (Uncorrected), F (lb.)		
	6" Sphere	7" Sphere	8" Sphere
1	15	15	17
2	15	15	17
3	14	15	17
4	14	15	17
5	15	15	17
6	15	15	17
7	14	15	17
8	14	15	17
9	15	15	17
10	15	15	17
Average: 14.6 lb. Average: 15 lb. Average: 17 lb. Std Dev.: 0.516 lb. Std Dev.: Zero Std Dev.: zero Corr. Avg.: 13.5 lb Corr. Avg.: 13.6 lb Corr. Avg.: 14.9 lb. Vacuum: -1 psi Vacuum: -1 to -2 psi Vacuum: -1 psi			

**Table VI. Release Force F_c :
Aqua Star Vented Riser Ring**

 I.D. = 6-3/4"		
Trial	Release Force (Uncorrected), F (lb.)	
	7" Sphere	8" Sphere
1	27	18
2	27	18
3	27	18
4	27	18
5	27	19
6	27	18
7	27	19
8	27	19
9	27	19
10	27	18
Average: 27 lb. Average: 18.4 lb. Std Dev. : Zero Std Dev. : 0.516 lb. Corr. Avg. : 25.6 lb Corr. Avg. : 16.3 lb. Pressure: 2 psi Pressure: -1 to - 2 psi		